

FAIRCHILD MODEL HPH

High Pressure Hydraulic Regulator

Installation, Operation and Maintenance Instructions

Introduction

Fairchild's High Pressure Reducing Regulator is suitable for 690 bar (10,000 psig) inlet and outlet hydraulic and pneumatic applications. The HPH model is designed for harsh environments and the ceramic ball valve has excellent wear resistance. A unique cartridge design allows for quick replacement of the main valve and filter minimizing downtime. The tapped exhaust port allows for convenient capture of vented media.

Features and Benefits

- Cartridge-style service insert allows quick change of the main valve and filter without removal or disassembly of the regulator
- Internal 40 micron supply filter protects pressure regulator and downstream equipment from incidental contamination
- Ceramic main valve provides superior performance and enhanced durability in extreme cavitation and erosion conditions
- Segregated captured vent for control of relief media

Applications

- Wellhead Control Panels (WHCP)
- Subsea Valve Actuator Control
- Harsh / Corrosive Environments
- Pressure Test Benches



Maximum Inlet Pressure

10,000 psig / 690 bar

Ambient Operating Temperature

-40°C to 80°C [-22°F to 176°F]

Flow Capacity

Main Valve: Cv = 0.09

Vent Valve: Cv = 0.11

Table 1 - Catalog No. Structure

Catalog Number			HPH	*	*	*	*	*
Model			HPH					
Pressure Range	PSIG	BAR	kPa					
	0-500	0-35	0-3500	1				
	0-1000	0-69	0-6900	2				
	0-1500	0-103	0-10300	3				
	0-3000	0-207	0-20700	4				
	0-5000	0-345	0-34500	5				
0-10000	0-690	0-69000	6					
Port Size	1/4				2			
Port Thread	NPTF						N	
	BSPT						U	
	SAE AS5202						S	
Elastomers	Nitrile		[Temp -40°C to +80°C]				N	
	Fluorocarbon		[Temp -20°C to +80°C]				J	
Relief	Relieving							R

Table 2 - Main Valve Replacement Cartridge

Part Number	22581-1	*
Elastomers	Nitrile	N
	Fluorocarbon	J

Table 3 - Mounting Bracket Kit

Part Number	22823-1
-------------	---------

FAIRCHILD MODEL HPH

High Pressure Hydraulic Regulator

Installation, Operation and Maintenance Instructions

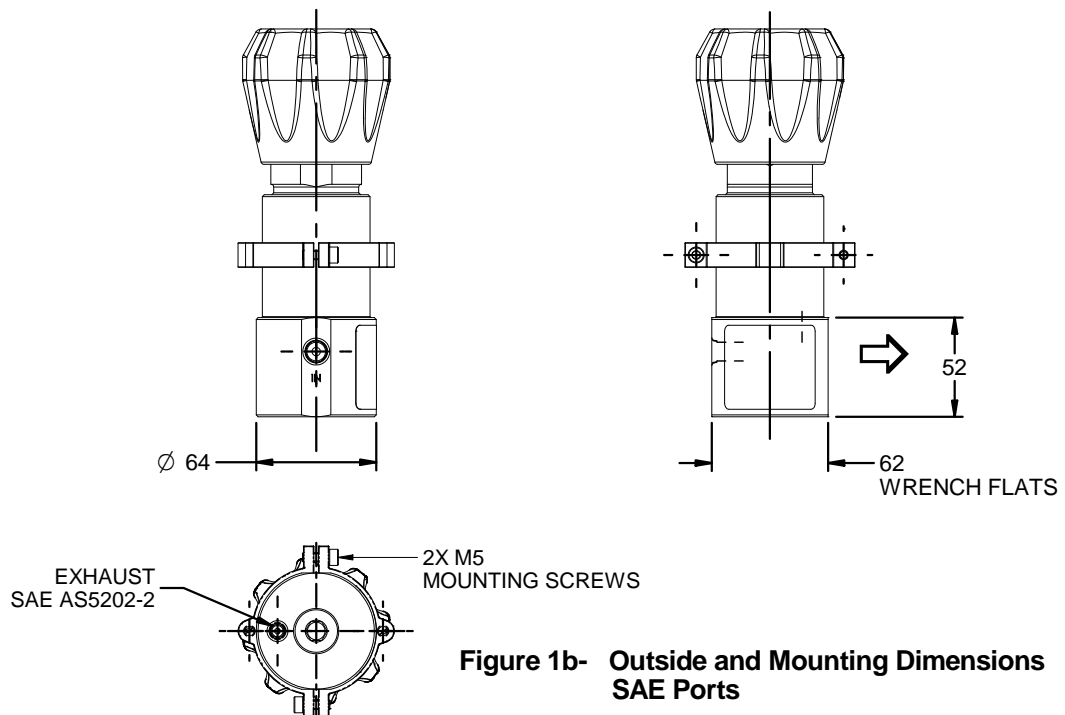
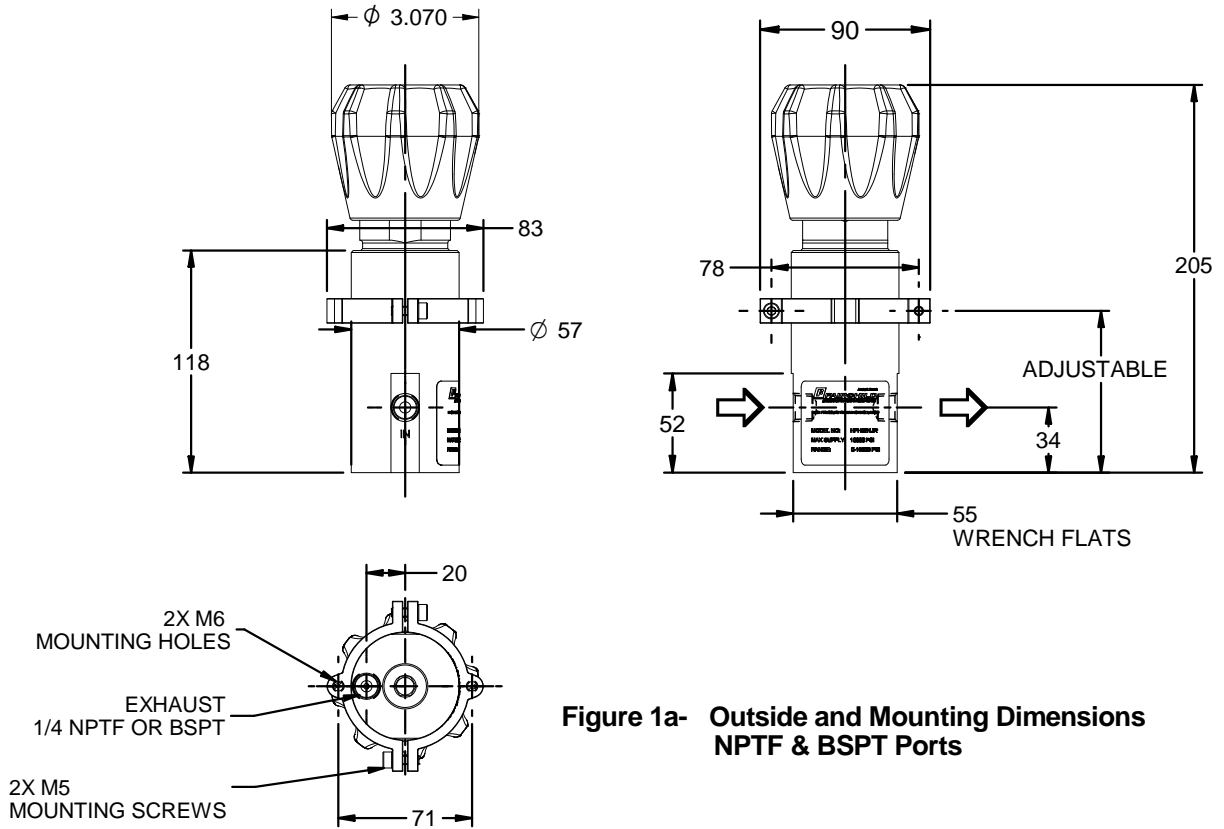

FAIRCHILD MODEL HPH

High Pressure Hydraulic Regulator

Installation, Operation and Maintenance Instructions

Installation Instructions

The pressure regulator may be mounted in any position without affecting its operation.

Clean all pipe fittings to remove contaminants before installation.

Apply a minimum amount of pipe compound or Teflon tape to the male threads of the fitting. Start with the second thread back and work away from the end of the fitting to avoid thread tape or compound from contaminating pressure regulator.

The Inlet and Outlet are labeled "IN" and "OUT". Apply a minimum amount of pipe compound or Teflon tape to the male threads of the fitting. Tighten all connections securely. Avoid undersized fittings that will limit flow through the regulator.

External size and mounting dimensions are detailed in Figures 1a & 1b.

Replace Main Valve Cartridge

NOTE: This is the recommended standard maintenance procedure. It replaces the main valve, valve seat, and all elastomers controlling high input pressure.

WARNING

It is critical that pressure is removed from the system before any maintenance is performed. Removing a fitting that is under high pressure could cause serious injury or death.

1. Shut off system pressure to the pressure regulator and relieve the pressure in all connected lines. It is not necessary to remove the pressure regulator from the system if space permits.
2. Remove the cartridge from the bottom of the regulator using a 10mm hex key.
3. Lubricate the o-rings on the replacement cartridge and install it using the 10mm hex key. Torque to approximately 15 ft-lb.
4. Reapply system pressure to the unit.

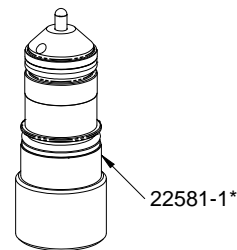
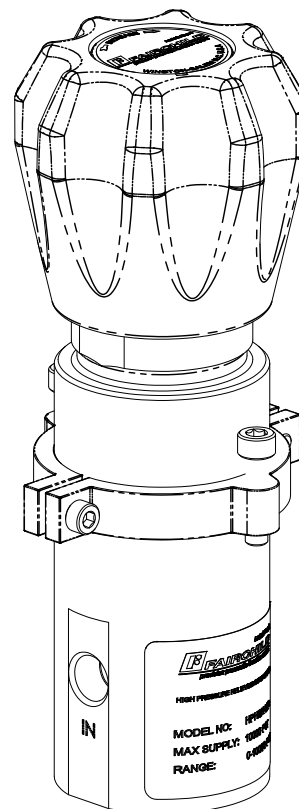

Body	316 Stainless Steel
Supply and Vent Seats	MP35N
Supply Valve	Zirconia Oxide Ceramic Ball
Internal Components	316 and 17-4 PH
Back-up Rings	PTFE
O-Rings	Nitrile or Viton (Fluorocarbon)

Figure 2- Replacing the Main Valve Cartridge

FAIRCHILD MODEL HPH

High Pressure Hydraulic Regulator

Installation, Operation and Maintenance Instructions

Replace Main Valve Cartridge & All Elastomers

NOTE: Replacing all elastomers in the HPH is not recommended. The main valve cartridge in Figure 2 was designed for easy and safe replacement of the main valve, filter, and primary elastomers. The following instructions detail a significant teardown of the HPH regulator and should only be performed by qualified personnel.

Lubricate all o-rings as they are installed.

1. Shut off system pressure to the pressure regulator and relieve the pressure in all connected lines. Turn the Knob CCW until it won't go any further. It may be necessary to remove the pressure regulator from the line.
2. Remove the Knob Cap using a small flat blade screwdriver.
3. Loosen Hex Nut on top of the Knob Assy using 13mm hex socket. Remove Nut and Washer and lift off the Knob.
4. Hold the Valve Body steady and remove the Bonnet using a large adjustable wrench.
5. Remove the Spring and Spring Seat.
6. Remove the Cartridge from the bottom of the regulator using a 10mm hex key and discard.
7. Turn the Valve Body over and push the Piston Housing Assy out the top using a $\varnothing 0.5 - \varnothing 0.625$ " dowel made of plastic or wood.
8. Separate Piston Housing Assembly as shown in Figure 4. Discard Piston, O-rings and Backup Ring.
9. Install new O-rings and Backup rings on the Piston Housing Assy, including the one that fits between the top and bottom parts of the Assembly.
10. Install the replacement Piston in the Assembly.
11. Install the replacement Cartridge into the Valve Body using a 10mm hex key. Torque to 15 ft-lb.
12. Press the Piston Housing Assembly into the Valve Body until it is fully seated.
13. Reinstall the Spring Seat and then the Spring.
14. Reinstall the Bonnet and torque to 130-150 ft-lb.
15. Reinstall the Knob and ensure it engages with the hex. Reinstall the washer and the Hex Nut. Torque the Nut to 15 ft-lb.
16. Reinstall the Knob Cap by pressing it into place.
17. Apply input pressure gradually to be sure all elastomers are sealing properly. Test the output pressure range in the same way.
18. Reapply system pressure to the unit.

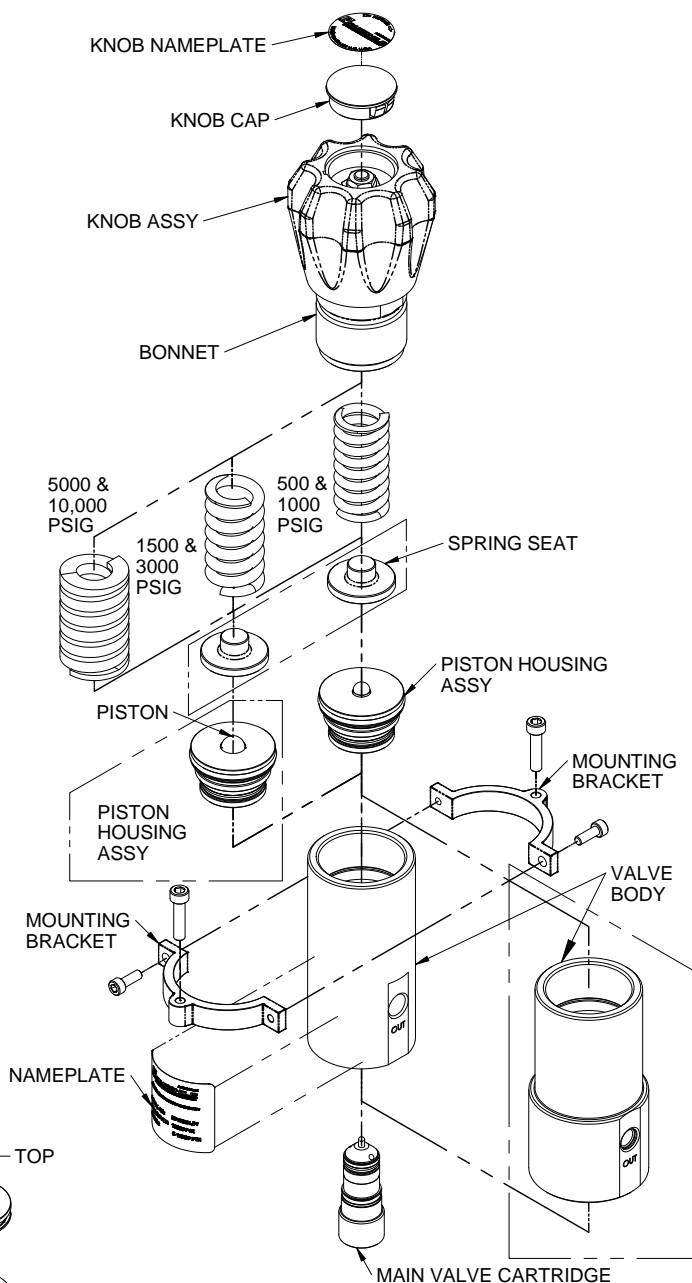

Figure 3- Replacing the Main Valve Cartridge & All Elastomers

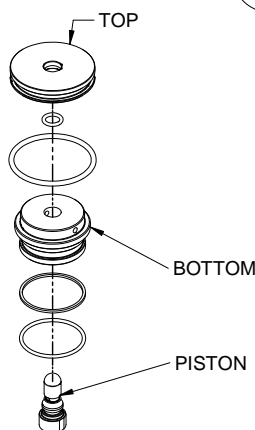

Figure 4- Piston Housing Assy Exploded View

