

# FINE CONTROLS (UK) LTD



Fine Controls have been supplying process controls & instrumentation equipment since 1994, & now serves an ever expanding customer base, both in the UK & globally.

We offer a full range of valve & instrumentation products & services, with our product range representing leading technologies & brands:

**Flow:** Flow Meters & Transmitters, Flow Switches, Flow Control Valves & Batch Control Systems

**Temperature:** Temperature Probes & Thermowells, Temperature transmitters, Temperature Regulators & Temperature Displays

**Level:** Level Transmitters & Switches

**Pressure:** Pressure Gauges & Transmitters, Precision & High Pressure Regulators & I-P Converters, Volume boosters.

**Precision Pneumatics:** Pressure Regulators, I-P Converters, Volume Boosters, Vacuum Regulators

**Valves:** Solenoid & Pneumatic Valves, Control Valves & Positioners, Actuated Ball, Globe or Diaphragm Valves & Isolation Valves

**Services:** Repair, Calibration, Panel Build, System Design & Commissioning

A rotork® Brand  
**FAIRCHILD**



**bürkert**



**SIEMENS**



**alcon**  
SOLENOID VALVES

A rotork® Brand



**MIDLAND-ACS**  
A rotork® Brand



**Honeywell**



**Bourdon**  
Baumer Group



**SOLDO**  
CONTROLS

A rotork® Brand



Fine Controls (UK) LTD, Bassendale Road, Croft Business Park,  
Bromborough, Wirral, CH62 3QL UK  
Tel: 0151 343 9966  
Email: sales@finecontrols.com

**SD74**

Rev. 19

January 2011

Supersedes Issue 18



## **Model Series 74 Valve Positioner and Motion Transmitter**

---

**TABLE OF CONTENTS**

<b>SECTION AND TITLE</b>	<b>PAGE</b>
<b>1.0 INTRODUCTION</b> .....	<b>4</b>
1.1 MODEL DESIGNATION .....	4
1.2 SPECIFICATIONS .....	4
1.3 ORDERING RANGE AND SUPPRESSION SPRING KITS .....	5
1.4 CUSTOMER/PRODUCT SUPPORT .....	7
<b>2.0 INSTALLATION</b> .....	<b>8</b>
2.1 PNEUMATIC CONNECTIONS .....	8
2.2 INSTRUMENT AIR REQUIREMENTS .....	8
2.3 VALVE POSITIONER .....	9
2.4 MOTION TRANSMITTER .....	9
2.5 RANGE AND SUPPRESSION SPRING KITS .....	12
2.5.1 Rectilinear Range Spring Kit .....	12
2.5.2 Rotary Range Spring Kit .....	12
2.5.3 Suppression Spring Kit .....	14
<b>3.0 CALIBRATION</b> .....	<b>15</b>
3.1 VALVE POSITIONER .....	15
3.1.1 Rectilinear Range Spring .....	15
3.1.2 Rotary Range Spring .....	15
3.2 OUTPUT PRESSURE LEVEL ADJUSTMENT .....	15
3.3 MOTION TRANSMITTER .....	16
<b>4.0 OPERATION</b> .....	<b>17</b>
4.1 VALVE POSITIONER .....	17
4.2 MOTION TRANSMITTER .....	18
<b>5.0 MAINTENANCE</b> .....	<b>19</b>
5.1 DISASSEMBLY .....	21
5.2 ASSEMBLY .....	22
5.3 PREVENTIVE .....	22
<b>6.0 PARTS LIST</b> .....	<b>23</b>

## LIST OF ILLUSTRATIONS

FIGURE AND TITLE	PAGE
2-1 Installation Dimensions .....	10
2-3 Rotary Range Spring Kit Assembly and Parts List .....	13
2-4 Rotary Range Spring Assembly .....	13
2-5 Mounting Plate .....	14
4-1 Valve Positioner Schematic .....	18
4-2 Motion Transmitter Schematic .....	19
5-1 Parts Comparison Models 74 and 74S .....	20
5-2 Upper Housing and Output Diaphragm .....	21
5-3 Diaphragm and Beam Assembly .....	22

## LIST OF TABLES

TABLE AND TITLE	PAGE
1-1 Rectilinear Range Spring Kits .....	5
1-2 Rotary Range Spring Kits .....	6
1-3 Zero Suppression Spring Kits .....	6
2-1 Double-Acting Cylinder Operators .....	11
2-2 Single-Acting Operators .....	11

### Changes for Revision 19, January 2011

Significant changes for this revision are indicated by change bars in the outside page margins. Some of these changes are listed below.

<b>CHANGE</b>
Cover banner updated; manual revision number and date changed.
Section 1.4 Customer/Product Support updated.
In Section 2.4, volume chamber part number deleted.
Warranty statements revised and moved to Section 1.4.

*All product designations may be trademarks or product names of Siemens Industry, Inc. or other supplier companies whose use by third parties for their own purposes could violate the rights of the owners.*

*Siemens Industry, Inc. assumes no liability for errors or omissions in this document or for the application and use of information in this document. The information herein is subject to change without notice.*

*Procedures in this document have been reviewed for compliance with applicable approval agency requirements and are considered sound practice. Neither Siemens Industry, Inc. nor these agencies are responsible for product uses not included in the approval certification(s) or for repairs or modifications made by the user.*

## 1.0 INTRODUCTION

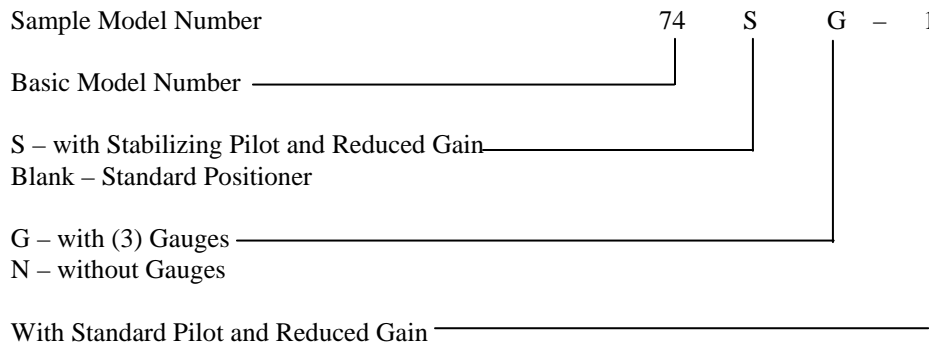
This instruction describes the installation, operation, and maintenance of the Model Series 74 Valve Positioner and Motion Transmitter. The Model Series 74 is a two-stage, high frequency response valve positioner. The positioner incorporates dual outputs which makes it ideally suited for double-acting cylinder operators. When one output is supplying air, the other is exhausting it. This action provides large differential forces to drive the actuator to the desired position. The Model Series 74 is also used as a single-acting positioner for spring type and cushion-load actuators. In this case, only one positioner output is used.

The Model 74S can be used as a motion transmitter. It delivers a 3-15 psig output for input motion spans from 1/4" to 48". For this application, a stabilizing restriction is added to the positioner piping. Normally the Model 74S is used on small-bore cylinder operators of limited volume (generally 4" I.D. and smaller).

### IMPORTANT

Save this Instruction and make it available for installation and maintenance of the instrument.

## 1.1 MODEL DESIGNATION



## 1.2 SPECIFICATIONS

Input Ranges ..... 3-15, 3-9, 3-27, 0-15 and 0-30 including split ranges within these basic ranges

Valve Stroke, Rectilinear Range Spring

Minimum ..... 1/4"

Maximum ..... 48"

Valve Stroke, Rotary Range Spring ..... 90° travel CW or CCW

Supply Pressure

Minimum ..... 3 psi above full actuator pressure required

Maximum ..... 150 psig

Ambient Temperature Limits ..... -40°C to +82°C (-40°F to +180°F)

The Model Series 74 has been designed and manufactured in accordance with Article 3, Paragraph 3 of Pressure Equipment Directive 97/23/EC.

### 1.3 ORDERING RANGE AND SUPPRESSION SPRING KITS

Order either a rectilinear spring kit or a rotary spring kit for each Model 74, depending upon the intended actuator.

- For a rectilinear actuator, refer to Table 1-1 and, considering actuator stroke length and Model 74 input pressure range, select the needed kit.
- For a rotary actuator, refer to Table 1-2 and, considering actuator direction of stem rotation and Model 74 input pressure range, select the needed kit.

For split ranges, also order a zero suppression kit from Table 1-3.

Section 2 Installation contains illustrations of most Model 74 parts including those in the kits mentioned here.

**TABLE 1-1 Rectilinear Range Spring Kits**

Figures 2-1 and 2-2 show the rectilinear range spring.

ACTUATOR STROKE IN INCHES	KIT AND PARTS	INSTRUMENT INPUT PRESSURE RANGE IN PSIG				
		3-15	3-9	3-27	0-30	0-15
1/4 to 1-1/2	Kit No.	14995-101	14995-114	14995-104	14995-107	14995-110
	Spring No.	14996-1	14996-4	14996-7	14996-10	14996-13
	Color Code	Black	Black-Red	Black-Yellow	Black-Orange	Black-Green
	Screw No.	12372-274	12372-274	12372-274	12372-274	12372-274
1-1/2 to 2-3/4	Kit No.	14995-102	14995-115	14995-105	14995-108	14995-111
	Spring No.	14996-2	14996-5	14996-8	14996-11	14996-14
	Color Code	White	White-Red	White-Yellow	White-Orange	White-Green
	Screw No.	12372-273	12372-273	12372-273	12372-274	12372-274
2-3/4 to 4	Kit No.	14995-103	14995-116	14995-106	14995-109	14995-112
	Spring No.	14996-3	14996-6	14996-9	14996-12	14996-15
	Color Code	Blue	Blue-Red	Blue-Yellow	Blue-Orange	Blue-Green
	Screw No.	12372-273	12372-273	12372-273	12372-292	12372-273
4 to 6	Kit No.	14995-119	Not Available			
	Spring No.	14996-102				
	Color Code	Brown				
	Screw No.	12372-292				
6 to 9	Kit No.	14995-117	14995-128	14995-126	Not Available	
	Spring No.	14996-104	14996-16	14996-107		
	Color Code	Green	Brown-Red	Green-Yellow		
	Screw No.	12372-292	12372-303	12372-303		
9 to 12	Kit No.	14995-120	14995-129	14995-127	Not Available	
	Spring No.	14996-106	14996-17	14996-108		
	Color Code	Red	Yellow-Red	Green-Red		
	Screw No.	12372-303	12372-303	12372-303		
12 to 19	Kit No.	14995-118	Not Available			
	Spring No.	14996-110				
	Color Code	Orange				
	Screw No.	12372-303				
19 to 36	Kit No.	14997-1	Not Available			
	Spring No.	14996-111 <sup>1</sup>				
	Color Code	None				
	Screw No.	12372-303				

Continued on next page

<sup>1</sup> Spring is factory cut for customer specified stroke.

**TABLE 1-1 Rectilinear Range Spring Kits, Continued**

ACTUATOR STROKE IN INCHES	KIT AND PARTS	INSTRUMENT INPUT PRESSURE RANGE IN PSIG				
		3-15	3-9	3-27	0-30	0-15
36-48	Kit No.	14997-1	Not Available			
	Spring No.	14996-111 <sup>2</sup>				
	Color Code	None				
	Screw No.	12372-296				
48	Kit No.	14995-121	Not Available			
	Spring No.	14996-111 <sup>2</sup>				
	Color Code	None				
	Screw No.	12372-296				

**TABLE 1-2 Rotary Range Spring Kits**

See Figure 2-3 for an exploded view of the kit and a parts list. A detailed view of the spring assembly appears in Figure 2-4. See Figure 2-5 for mounting plate dimensions.

MOUNTING PLATE SUPPLIED	ROTATION OF ACTUATOR SHAFT	CLOCKWISE		COUNTERCLOCKWISE	
	Instrument Input Range in psig	3-9	3-15	3-9	3-15
Kit <u>Without</u> Mounting Plate	Kit No.	14923-152	14923-154	14923-102	144923-104
	Spring Assy. No.	14923-72	14923-70	14923-73	14923-71
	Color Code	Green	White	Black	Red
Kit <u>With</u> Mounting Plate	Kit No.	14923-151	14923-153	14923-101	14923-103
	Spring Assy. No.	14923-72	14923-70	14923-73	14923-71
	Color Code	Green	White	Black	Red
	Mounting Plate	14923-52	14923-52	14923-52	14923-52

**TABLE 1-3 Zero Suppression Spring Kits**

Zero suppression spring kits include a suppression spring and a spring seat. All kits include the P/N 12372-254 spring seat (not listed below). See Figure 2-6. The zero suppression spring affects only the zero level by the fixed amount shown and has no effect on stroke or span.

SUPPRESSION IN PSIG	ORDER KIT NO.	INCLUDES SPRING NO.	SPRING COLOR CODE
2.5	12517-201	12497-1	Black
6	12517-202	12497-2	Orange
9	12517-208	12497-8	Brown
11	12517-204	12497-4	Red
12	12517-205	12497-5	Green
14	12517-206	12497-6	White

<sup>2</sup> Spring is factory cut for customer specified stroke.

## 1.4 CUSTOMER/PRODUCT SUPPORT

For support and the location of your local Siemens representative, refer to the table below for the URL of the Process Instrumentation (PI) portion of the Siemens public Internet site. Once at the site, click **Support** in the right column and then **Product Support**. Next select the type of support desired: sales, technical (see the table below), documentation, or software.

Online Support Request	<a href="http://www.siemens.com/automation/support-request">http://www.siemens.com/automation/support-request</a>
Technical Support	1-800-333-7421; 8 a.m. to 4:45 p.m. eastern time, Monday through Friday (except holidays)
Customer Service & Returns	1-800-365-8766 (warranty and non-warranty)
Public Internet Site	<a href="http://www.usa.siemens.com/pi">http://www.usa.siemens.com/pi</a>
Technical Publications in PDF	Click the above link to go to the PI home page. Click <b>Support</b> and then <b>Manuals</b> and then, under "Additional Manuals," select the product line (e.g. Control Solutions)

### Warranty

The sales contract contains the entire obligation of Siemens. The warranty contained in the contract between the parties is the sole warranty of Siemens. Any statements continued herein do not create new warranties or modify the existing warranty.



## 2.0 INSTALLATION

See Figure 2-1 for mounting dimensions and connections. The two basic mounting positions of the positioner are normal, where the nameplate is on the bottom, and inverted, where the nameplate is on top. Valve design and desired valve position when the input is at maximum determine whether the positioner should be mounted normal or inverted. Table 2-1 shows various positioner-actuator combinations when using a double-acting cylinder operator. Table 2-2 shows various positioner-actuator combinations when using a single-acting spring-loaded or cushion-loaded actuator. In both the single-acting and double-acting combinations, a fail-safe action is provided.

### CAUTION



Exceeding the specified ambient temperature limits can adversely affect performance and may cause damage.

## 2.1 PNEUMATIC CONNECTIONS

All connections are 1/4" N.P.T. except the gauge connections, which are 1/8" N.P.T. The recommended piping for the positioner is 1/4" O.D. tubing, although any scale-free piping may be used. When making pneumatic connections:

1. Blow out all piping before making connections to prevent dirt, chips, etc., from entering the positioner.
2. Use pipe sealant sparingly, and only on the male threads. A non-hardening sealant is strongly recommended.
3. Connect the positioner to a source of clean, dry, oil-free instrument air. See Instrument Air Requirements below.

### CAUTION



Pressure in excess of 150 psig to any connection may cause damage.

## 2.2 INSTRUMENT AIR REQUIREMENTS

Connect the instrument to a source of clean, dry, oil-free instrument air. Failure to do so will increase the possibility of a malfunction or deviation from specified performance.

### CAUTION



Use of process fluids other than instrument air is not recommended. No claim is made as to the suitability of this product for use with other process fluids, such as hazardous gases, except as listed on the appropriate certificate. Non-approved instruments are suitable for use with instrument air only. Optional features and modifications such as tapped exhaust do not imply suitability for use with hazardous gases except as listed on the approval certificate.

There are many types of synthetic compressor lubricants. Some may not be compatible with the materials used in construction of the instrument. Wetting of these materials by such an oil mist or vapor, etc., may cause them to deteriorate. This may ultimately result in failure of the positioner. The following materials are in contact with instrument air: aluminum, brass, Buna-N, and stainless steel.

**CAUTION**

Synthetic compressor lubricants in the air stream at the instrument may cause it to fail.

The requirements for a quality instrument air supply can be found in the Instrument Society of America's "Quality Standard for Instrument Air" (ISA-S7.3). Basically, this standard calls for the following:

**Particle Size** — Maximum particle size in the air stream at the instrument should be no larger than 3 microns.

**Dew Point** — The dew point, at line pressure, should be at least 10°C (18°F) below the minimum temperature to which any part of the instrument air system is exposed at any season of the year. Under no circumstances should the dew point, at line pressure, exceed 2°C (35.6°F).

**Oil Content** — Maximum total oil or hydrocarbon content, exclusive of non-condensable, should not exceed 1 ppm under normal operating conditions.

## **2.3 VALVE POSITIONER**

### **Single-Acting**

When used as a single-acting valve positioner, the Model 74 uses one output connection. If the VALVE 2 connection is used, an increase in output must increase range spring (feedback) tension. If the VALVE 1 connection is used, an increase in output must decrease range spring (feedback) tension. In either case, the connection not chosen must be plugged.

### **Double-Acting**

When used as a double-acting valve positioner, the Model 74 uses both the VALVE 1 and VALVE 2 connections. In this case, an increase in output must increase range spring (feedback) tension.

## **2.4 MOTION TRANSMITTER**

When used as a motion transmitter, the VALVE 1 connection is the transmitter output; plug the VALVE 2 connection. To use the Model 74S as a motion transmitter, order the P/N 14411-7 restriction fitting and install as shown in Figure 4-2. For input motions greater than 12" and an output line that is less than 50 feet, install a volume chamber in the output line to insure stable operation.

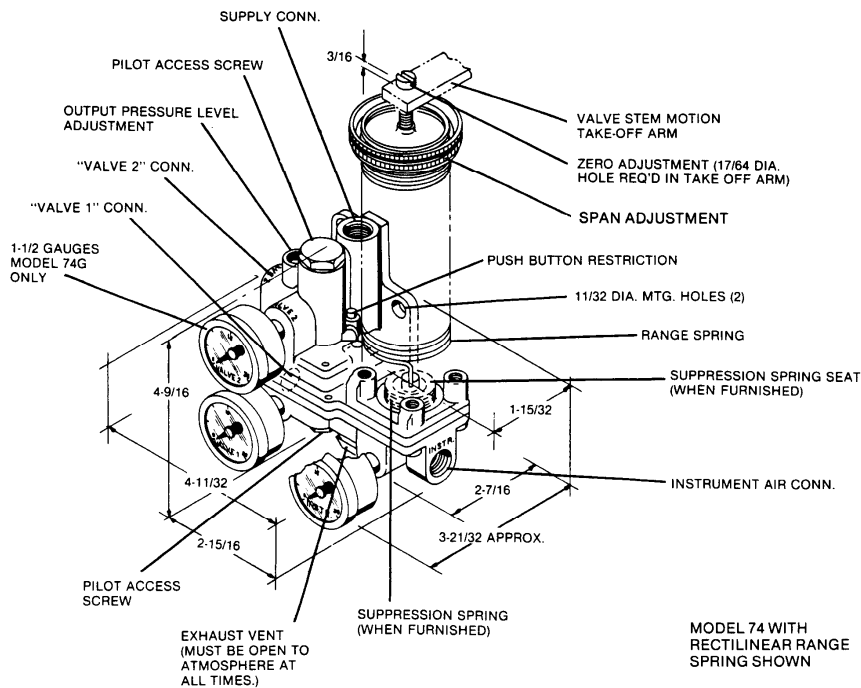
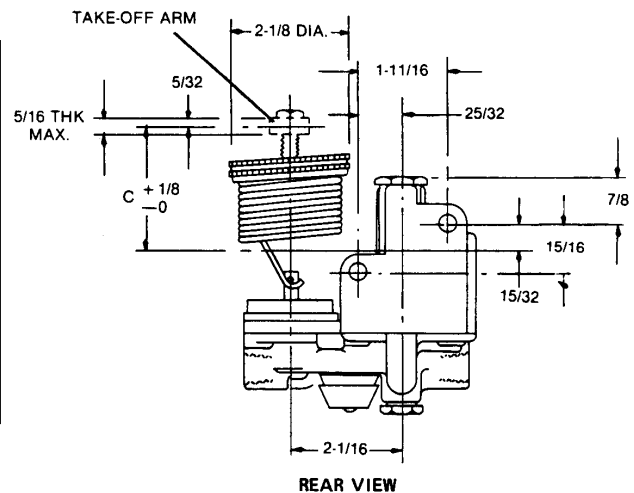
6 PSI INSTR. PRESS. SPAN.		12 PSI INSTR. PRESS. SPAN		15 PSI INSTR. PRESS. SPAN		24 PSI INSTR. PRESS. SPAN		30 PSI INSTR. PRESS. SPAN	
Stroke	"C" Dim.	Stroke	"C" Dim.	Stroke	"C" Dim.	Stroke	"C" Dim.	Stroke	"C" Dim.
1/4 to 1-1/2	1-1/2	1/4 to 1-1/2	1-5/16	1/4 to 1-1/2	1-9/32	1/4 to 1-1/2	1-17/32	1/4 to 1-1/2	1-19/32
1-1/2 to 2-3/4	2-9/32	1-1/2 to 2-3/4	2-7/32	1-1/2 to 2-3/4	2-7/32	1-1/2 to 2-3/4	2-9/32	1-1/2 to 2-3/4	2-9/32
2-3/4 to 4	3-9/32	2-3/4 to 4	3-7/32	2-3/4 to 4	3-5/32	2-3/4 to 4	3-1/4	2-3/4 to 4	3-5/32
		4 to 6	4-1/2						
6 to 9	5-31/32	6 to 9	5-3/4			6 to 9	7-1/2		
9 to 12	7-23/32	9 to 12	8-9/16			9 to 12	9-5/8		
		12 to 19	12-1/32						
		19 to 37	*						
		37-48	*						
		48	*						

All dimensions in inches. \* Calculate as shown below.

**"C" Dimension** for strokes 19" or longer, with 3-15 psi instrument pressure range =  $0.68 \times \text{stroke}$ .  
Example: 19" stroke,  $C = 0.68 \times 19 = 12.92$ "

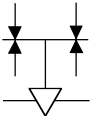
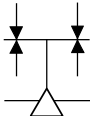
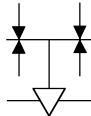
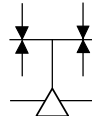
**Notes:**

- 1) All connections 1/4 NPT with exception of 1/8 NPT gauge connections.
- 2) Increase in instrument air causes increase in pressure at "Valve 2" connection. "Valve 2" pressure must be applied to actuator so as to extend range spring and restore balance.

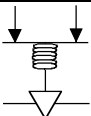
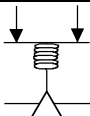
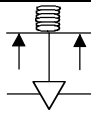
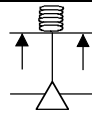


**FIGURE 2-1 Installation Dimensions**

**TABLE 2-1 Double-Acting Cylinder Operators**

<b>VALVE DESIGN</b>				
Valve Action	Down to Close	Up to Close	Down to Close	Up to Close
Maximum Controller Output, Valve	Closes	Opens	Opens	Closes
For Controller Air Failure, Valve	Opens	Closes	Closes	Opens
Positioner Mounting	Inverted	Inverted	Normal	Normal

**TABLE 2-2 Single-Acting Operators**

<b>VALVE DESIGN</b>								
Actuator	Top	Top	Bottom	Bottom				
Valve Action	Air Closes	Air Opens	Air Opens	Air Closes				
Desired Valve Action								
Maximum Controller Output, Valve	Closes	Opens	Opens	Closes	Opens	Closes	Closes	Opens
For Controller Air Failure, Valve	Opens	Closes	Closes	Opens	Closes	Opens	Opens	Closes
For Positioner Supply Air Failure, Valve	Opens	Opens	Closes	Closes	Closes	Closes	Opens	Opens
Mounting Position	Inverted	Normal	Inverted	Normal	Normal	Inverted	Normal	Inverted
Port to be Connected to Actuator	Valve 2	Valve 1	Valve 2	Valve 1	Valve 2	Valve 1	Valve 2	Valve 1
Port to be Plugged	Valve 1	Valve 2	Valve 1	Valve 2	Valve 1	Valve 2	Valve 1	Valve 2

## 2.5 RANGE AND SUPPRESSION SPRING KITS

There are three spring kits: rectilinear range, rotary range, and suppression. Each is packaged separately and is assembled on the Model 74 by the instrument installer. Available kits are listed in Section 1.3. Springs are color-coded and spring colors are included in the tables in Section 1.3.

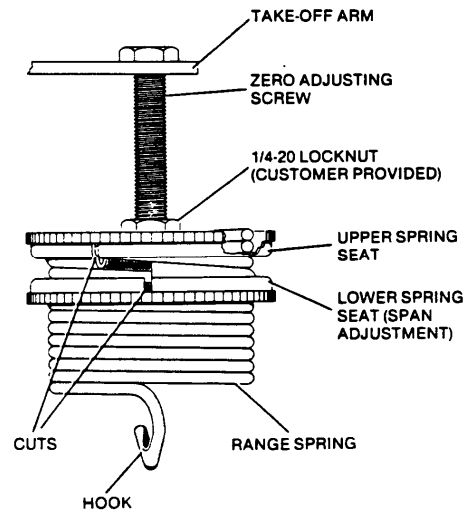
### IMPORTANT

Install the suppression spring kit (if needed) before installing a range spring kit; see Section 2.5.3 Suppression Spring Kit.

### 2.5.1 Rectilinear Range Spring Kit

Refer to Figure 2-2 and the following procedure to assemble the range spring kit on the Model 74. Table 1-1 lists available rectilinear range spring kits and the color code for each spring.

1. Set the lower spring seat, knurled edge down, on the range spring.
2. Start the spring through the cut in the spring seat and turn three revolutions counterclockwise.
3. Set the upper spring seat, knurled edge up, on the range spring.
4. Start the spring through the cut in the spring seat and turn two revolutions counterclockwise. There should be one coil between spring seats.
5. Attached the range spring hook to the input diaphragm assembly stem (see Figure 4-1).
6. Insert the zero adjusting screw through the take-off arm into the spring seats (see Figure 2-2).
7. Refer to the Section 3 Calibration and calibrate the Model 74.
8. Turn the upper spring seat clockwise to lock the zero screw in place. The cut on the upper spring seat will be approximately 3/4" away from the cut on the lower spring seat when locked.



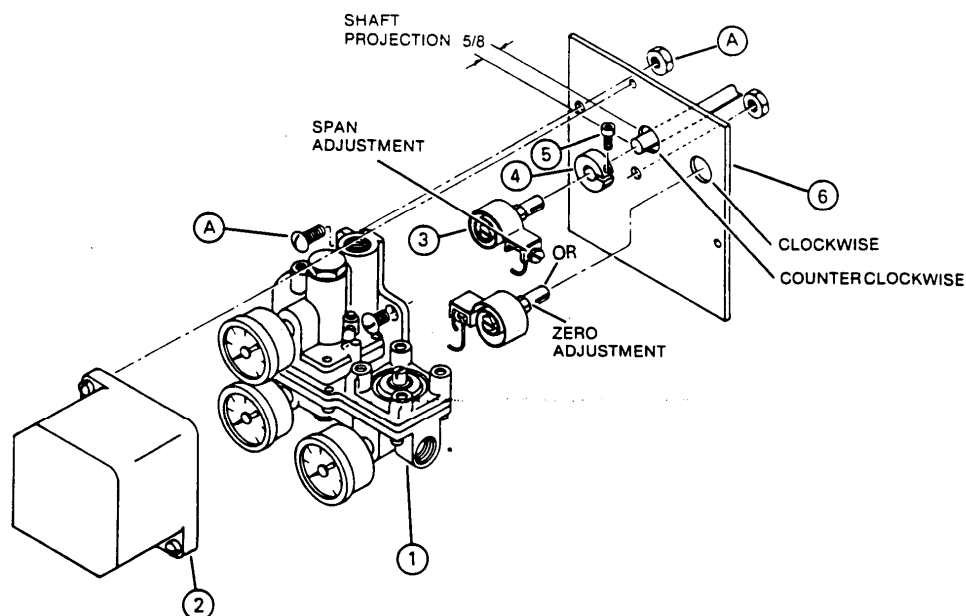
**FIGURE 2-2 Rectilinear Range Spring Kit - Assembled**

### IMPORTANT

If the Model 74 is mounted where severe vibration may be encountered, the locknut shown in Figure 2-2 should be installed. Tighten the 1/4-20 locknut against the upper spring seat.

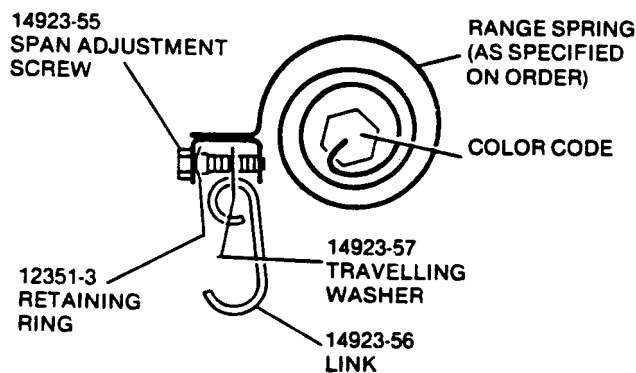
### 2.5.2 Rotary Range Spring Kit

See Figure 2-3 and the following procedure to assemble the rotary range spring kit on the Model 74. Figure 2-4 shows the common parts of a rotary range spring assembly. Range spring assemblies listed in Table 1-2 differ only in the range spring required. Range springs are color-coded and spring colors are listed in Table 1-2.



ITEM	DESCRIPTION
1	Model 74
2	Enclosure Assembly
3	Spring Assembly (includes: range spring, traveling washer, span adjusting screw, and link)
4	Split Clamp
5	6-32 x 3/8 lg. Socket Hd. Screw
6	Mounting Plate, when ordered; plate mounting hardware (A) is installer supplied

**FIGURE 2-3 Rotary Range Spring Kit Assembly and Parts List**



ALL PARTS SHOWN ARE COMMON TO ALL  
ROTARY RANGE SPRING ASSEMBLIES  
EXCEPT FOR THE RANGE SPRING ITSELF.

**FIGURE 2-4 Rotary Range Spring Assembly**

1. If a kit without a mounting plate was ordered, fabricate a plate. Refer to the dimensions in Figure 2-5. The valve actuator shaft must have a diameter of 0.3125" ( $\pm 0.001$ ").
2. Fasten the mounting plate to the actuator. Ensure that the actuator shaft is in the correct hole in the mounting plate for the direction of rotation.
3. Place split clamp on actuator shaft. Do not tighten.

4. Place range spring assembly on actuator shaft.
5. Attach the range spring link to the input diaphragm assembly stem (See Figure 4-1).
6. Align the split clamp so that its slot is 90° from the slot in the range spring assembly. Tighten slightly.
7. Position the traveling washer on the span adjustment screw in its approximate center.
8. Calibrate the Model 74. Refer to Section 3 Calibration.
9. Lock the split clamp in place by tightening the clamp screw. Torque to 15-20 in lbs.

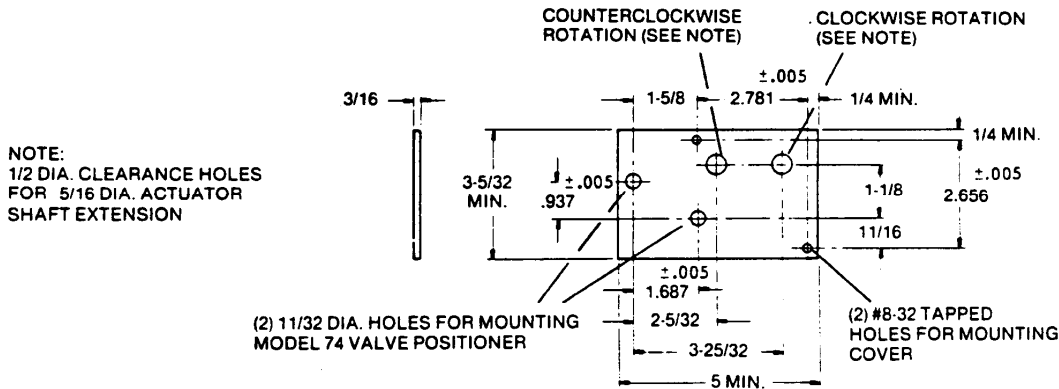


FIGURE 2-5 Mounting Plate

### 2.5.3 Suppression Spring Kit

For split ranging and for a range that starts at a pressure greater than 3 psig, add a suppression spring kit to the Model 74 range spring kit. Table 1-3 lists available zero suppression spring kits. Install the suppression spring kit before attaching the range spring to the input diaphragm assembly. Refer to the Parts List, Figure 2-6, and the following procedure to install the kit.

1. Remove the grommet and baffle from the input diaphragm assembly stem. The grommet and baffle will slide off.
2. Place the suppression spring on the housing.
3. Place the spring seat on the suppression spring.
4. Depress the spring and spring seat, aligning the input diaphragm assembly stem through the hole in the spring seat.
5. Attach the range spring hook to the input diaphragm assembly stem. No adjustment or calibration is necessary.

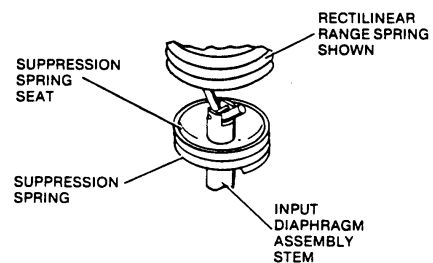


FIGURE 2-6 Suppression Spring Kit - Assembled

#### NOTE

The grommet and baffle are not re-installed with a suppression kit. They can be kept for future use or discarded.

## 3.0 CALIBRATION

### 3.1 VALVE POSITIONER

The Model 74, when used as a valve positioner, has three calibration adjustments: Zero, span and output pressure level. Make all adjustments with the positioner mounted on the actuator.

#### 3.1.1 Rectilinear Range Spring

ZERO AND SPAN (See Figure 2-2)

1. Turn on supply air.
2. Set input signal at its minimum range pressure (3 psig for a 3 to 15 psig range).
3. Loosen the range spring seats and turn the zero screw until the take-off arm just starts to move from its minimum stroke position.
4. Set input signal at its maximum range pressure (15 psig for a 3 to 15 psig range).
5. Turn the spring seats at the same time to reduce or increase the number of active coils of the spring. Turn the seats until the take-off arm just starts to move from its maximum stroke position.
6. Repeat steps 2 through 5 until the desired stroke is attained.
7. Lock the zero screw by holding the lower spring seat and turning the upper spring seat clockwise approximately 3/4".
8. Go to Section 3.2 Output Pressure Level Adjustment.

#### 3.1.2 Rotary Range Spring

ZERO AND SPAN (See Figure 2-3)

1. Turn on supply air.
2. Set input signal at its minimum range pressure (3 psig for a 3 to 15psig range).
3. Slightly loosen the split clamp screw. Using a 3/8" open-end wrench, turn the zero adjustment until the valve actuator is at its starting point.

Check the zero by adjusting the input signal below 3 psig; slowly increase the input signal; the actuator should start to move when the input signal crosses 3 psig.

4. Set the input signal to its maximum range pressure (9 or 15 psig).
5. Set the span adjustment screw so that the actuator shaft assumes its maximum rotation.

Check the span by adjusting the input signal above maximum range pressure; slowly decrease the input signal; the actuator should start to move when the input signal crosses maximum range pressure.

6. Check and reset the zero adjustment if necessary.
7. Repeat steps 2-6 as necessary to obtain the desired zero and span settings.
8. Tighten split clamp screw.
9. Go to Section 3.2 Output Pressure Level Adjustment.

### 3.2 OUTPUT PRESSURE LEVEL ADJUSTMENT

The output pressure level adjustment is used to:

- Set the optimum output pressure of positioners used on valves with double-acting actuators
- Place the unused pilot plunger out of operation in positioners used on valves with single-acting actuators.



This section gives a procedure for each type of actuator.

**Needed equipment:**

1. A pressure regulator capable of providing a mid-scale input for the positioner input range.
2. Three pressure gauges: one for the input and one for each of the positioner valve connections. Additional gauges are not required if the positioner is equipped with optional gauges.
3. A medium slotted screwdriver

**Double-Acting Actuators**

The output pressure level adjustment permits the pressure in the actuator chambers to be varied as desired. The optimum actuator pressure level setting for equal speed of operation in both directions is approximately 75% of supply pressure.

1. Make certain that there is no process force on the valve by removing or isolating the valve from the process.
2. Connect gauges to the input and valve connections, if required.
3. Turn on positioner supply.
4. Set the input (instrument) signal at mid-scale, e.g. 9 psig for a 3 to 15 psig input range. Allow actuator pressures to stabilize.
5. Turn the output level adjustment screw (see Figure 2-1) to obtain a reading approximately 75% of supply pressure.

After making this adjustment, allow sufficient time for the pressure to stabilize. Identical valve gauge readings should not be expected since the areas on the two sides of a piston or diaphragm may be somewhat different, due to the stem, thus requiring a slightly higher pressure to balance an opposing force.

**Single-Acting Actuators**

A positioner used on single-acting actuator has one valve connection plugged, thus one plunger is not used. The output pressure level adjustment is made to place the unused plunger out of operation.

1. Connect gauges to the input and valve connections, if required.
2. Turn on positioner supply.
3. Set the input (instrument) signal at mid-scale, e.g., 9 psig for a 3 to 15 psig input range.
4. Turn the output level adjustment screw clockwise (approximately two turns) until the pressure in the unused valve port falls to 0 psig).

**3.3 MOTION TRANSMITTER**

The Model 74S Motion Transmitter has zero and span adjustments. The output pressure level adjustment is not used.

**Rectilinear Range Spring**

ZERO AND SPAN (See Figures 2-1 and 4-2)

1. Connect the VALVE 1 (output) port to a test gauge or mercury manometer.
2. Turn the output pressure level adjustment screw clockwise until seated.
3. Plug the VALVE 2 port with 1/4" NPT pipe plug.
4. Turn on 20 psig supply air.
5. Position the valve to its minimum stroke position.

6. Loosen the spring seats and adjust the zero screw for a 3 psig output.
7. Position the valve to its maximum stroke position.
8. Turn both spring seats at the same time to increase or decrease the number of active coils, for a 15 psig output.
9. Repeat steps 5 through 8 until the transmitter is calibrated.
10. Lock the zero screw by holding the lower spring seat and turning the upper spring seat clockwise approximately 3/4".

## Rotary Range Spring

ZERO AND SPAN (Figures 2-1 and 2-3)

1. Connect the VALVE 1 (output) port to a test gauge or mercury manometer.
2. Turn the output pressure level adjustment screw clockwise until seated.
3. Plug the VALVE 2 port with a 1/4" NPT pipe plug.
4. Turn on supply air.
5. Position the valve to its minimum stroke position.
6. Slightly loosen the split clamp; use a 3/8" open-end wrench to turn the zero adjustment for a 3 psig output.
7. Position the valve to its maximum stroke position.
8. Turn the span adjustment screw for a 15 psig output.
9. Repeat steps 5 through 8 until the transmitter is calibrated.
10. Tighten split clamp screw.

## 4.0 OPERATION

### 4.1 VALVE POSITIONER

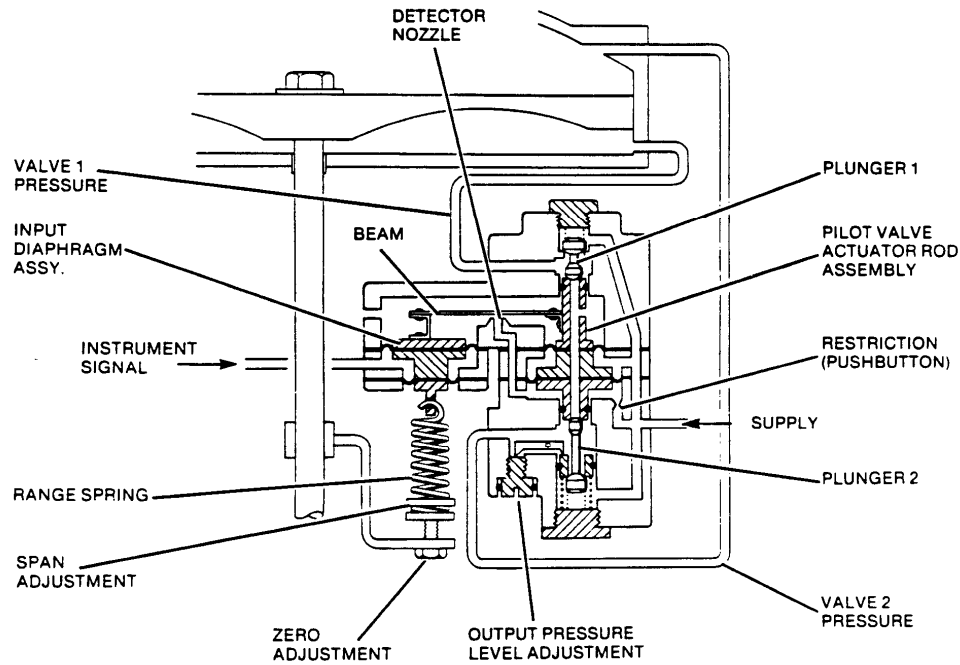
The positioner operates on a force-balance principle. The forces are: range spring tension and the pressure level of the instrument signal. The two forces oppose each other at the input diaphragm assembly. The positioner will move the valve until the tension of the range spring equals the force of the control instrument signal at the input diaphragm assembly.

Figure 4-1 shows the positioner connected to a double-acting piston operator. Here a balanced condition exists with the valve at mid-position. When the instrument signal pressure is increased, the resultant force on the input diaphragm assembly exceeds the tension on the range spring and the assembly moves up. The upward movement increases the clearance between the beam and detector nozzle, causing a decrease of pressure in the nozzle circuit. The decreasing pressure unbalances the forces across the lower diaphragm of the pilot valve actuator rod assembly and causes the assembly to move down. The downward movement pushes the PLUNGER 2 off its supply seat increasing the VALVE 2 pressure. At the same time, PLUNGER 1's exhaust seat, which is part of the pilot valve actuator rod assembly, moves away from the plunger. VALVE 1 pressure thus decreases as the air is exhausted to atmosphere.

The resultant pressure differential across the valve actuator piston moves the piston downward and thereby increases the range spring tension. As a force-balance condition is approached, VALVE 1 and VALVE 2 pressures begin to equalize. At balance, the pilot valve actuator rod assembly has moved back to the neutral position where the plungers are neither supplying air to, nor exhausting air from, the piston operator.

A decrease of the instrument signal pressure reverses all of the foregoing actions and results in an upward movement of the actuator piston and valve stem.

On spring-loaded and cushion-loaded operators, only one of the positioner outputs is used; the other is plugged. The Model 74 is then a single-acting positioner, working against the operator spring force or cushion load. The previous principle of operation describing the double-acting positioner applies also to the single-acting positioner.



**FIGURE 4-1 Valve Positioner Schematic**

## 4.2 MOTION TRANSMITTER

The Motion Transmitter works on the force-balance principle. The forces are comprised of range spring tension and the feedback signal pressure. These oppose each other at the input diaphragm assembly. The transmitter will vary the output, which feeds back through a restriction to the input diaphragm assembly. The resultant force balances the force exerted by the range spring tension at the input diaphragm assembly.

Figure 4-2 shows the motion transmitter connected to an input motion linkage arm. A downward movement of the linkage arm increases tension on the range spring. The resultant downward force exceeds the opposing force of the feedback signal on the input diaphragm assembly, causing the assembly to move down. This movement decreases the clearance between the beam and detector nozzle and causes an increase of pressure in the nozzle circuit. The increase of pressure unbalances the forces across the lower diaphragm of the pilot valve actuator rod assembly and causes the assembly to move upward. This movement pushes PLUNGER 1 off its supply seat, increasing the output pressure.

The output pressure is fed back through the stabilizing restriction into the input diaphragm assembly. This pressure increases until it exerts a force on the input diaphragm assembly equal to that applied by the range spring tension. When in balance, the input diaphragm assembly has moved to a neutral position. The actuator rod assembly has closed the pilot supply, thus maintaining the feedback pressure at the balance level.

When the motion arm moves upward, spring tension decreases and the foregoing actions are reversed. The actuator rod assembly will exhaust the output pressure until it reaches the balance level.

The VALVE 1 port is the only one used in the transmitter. The VALVE 2 port is plugged; therefore, PLUNGER 2 has no effect on transmitter operation.

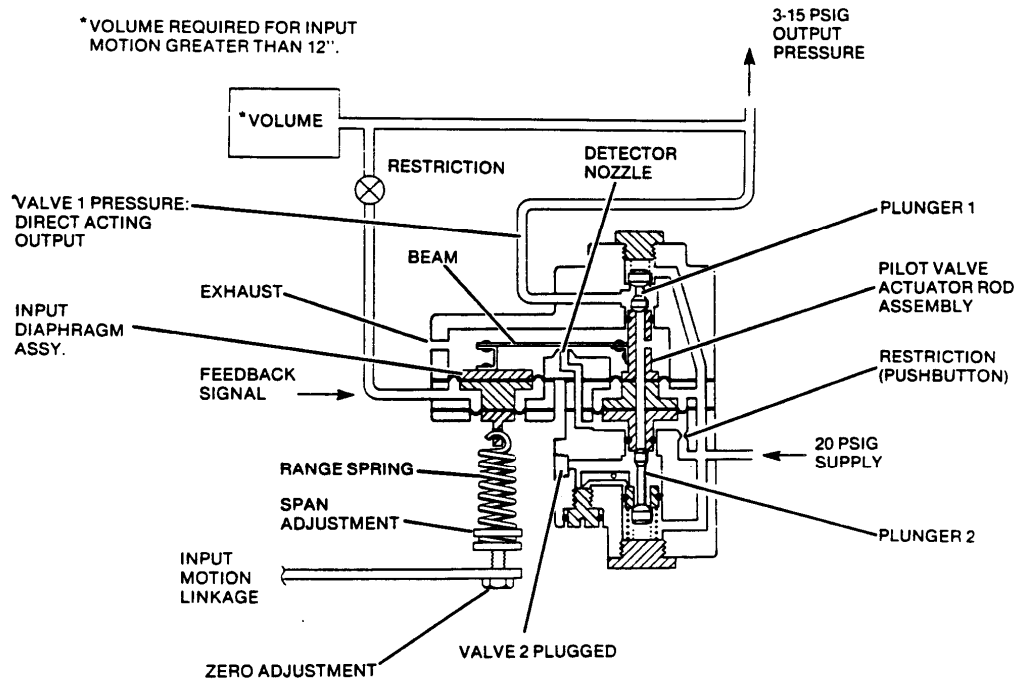


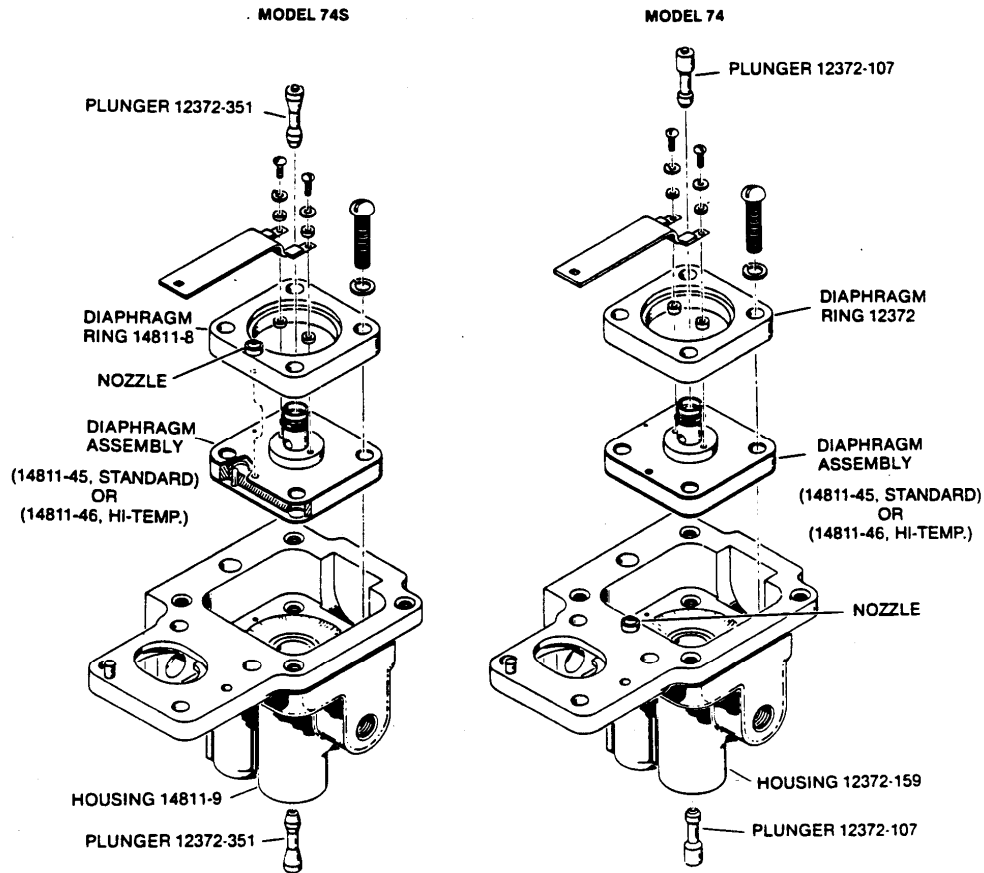
FIGURE 4-2 Motion Transmitter Schematic

## 5.0 MAINTENANCE

A spring return pushbutton restriction cleaner is built into the body of the valve positioner. Push this button to clear the restriction and eliminate problems caused by build-up on the restriction. Pushing the button will not interrupt operation of the valve.

A build-up of dirt on the pilot plungers or their seats may cause erratic operation. To clean these, turn off the supply, remove the retaining nuts, and drop the plungers out. Use a pipe cleaner and solvent to clean the plunger seats.

There are several parts that differ between the Models 74 and 74S. Figure 5-1 shows a side-by-side comparison of the variable parts.



- Plungers – The plungers differ in shape, as shown in this figure.
- Diaphragm Rings – The Model 74S diaphragm ring has a nozzle. The Model 74 ring does not.
- Diaphragm Assemblies – The Model 74S has a diaphragm spacer with a small hole drilled in it, as shown by the cutaway view in this figure. The Model 74 spacer does not have this hole.
- Housings – The housing for the Model 74 has a positioner nozzle. The Model 74S housing does not.

**FIGURE 5-1 Parts Comparison Models 74 and 74S**

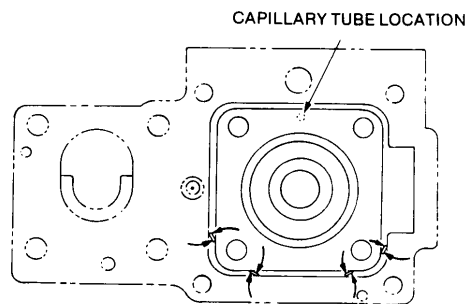
## 5.1 DISASSEMBLY

If it is necessary to disassemble the positioner, refer to Parts List No. 12372PL and proceed as follows:

1. Remove the pilot plunger sealing screws, plunger springs and plungers.
2. Remove the six body screws and separate the upper and lower housings.
3. Pull the baffle and grommet from the input diaphragm assembly stem.
4. Remove the two small screws that hold the beam to the output diaphragm assembly. Be careful not to lose the spacers and washers.
5. Remove the nut that holds the beam on the input diaphragm assembly and remove the beam.
6. Remove the two screws that hold the input diaphragm assembly housing to the bottom housing.
7. Separate the diaphragms of the input diaphragm assembly from the input and upper housings.
8. Remove the input housing and slide the input diaphragm assembly out of the upper housing.
9. Remove the four screws holding the output diaphragm assembly to the upper housing.



There is a blind capillary tube that cannot be seen until the output diaphragm assembly is removed from the upper housing. This small capillary tube is easily damaged if undue prying or force is used to separate the output diaphragm assembly from the upper housing. See Figure 5-2 and Step 10 for removal instructions.



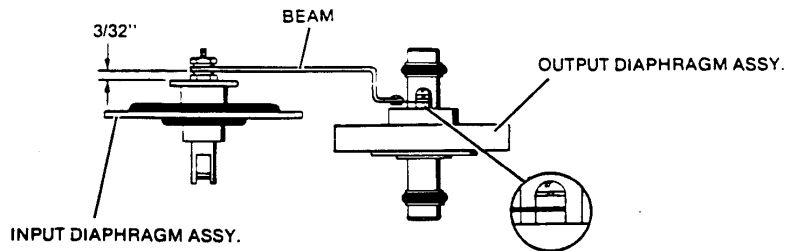
**FIGURE 5-2 Upper Housing and Output Diaphragm**

10. Insert a screwdriver between the upper housing and the output diaphragm assembly at the locations shown by the arrows in Figure 5-2. Twist the screwdriver in the direction indicated by the arrows. Twist only enough to just move the output diaphragm assembly. Do not pry!
11. Once the output diaphragm assembly is loosened from the upper housing, pull it straight out of the upper housing. A slight wiggling motion may be required.
12. Sometimes the clamping plate will separate from output diaphragm assembly before this assembly is separated from the upper housing. If it does not, separate the clamping plate after the output diaphragm assembly has been removed from the upper housing.
13. Clean and inspect all parts for wear or damage and replace if necessary.

## 5.2 ASSEMBLY

To assemble, reverse the disassembly procedure and take into account the following:

1. Exercise care when installing the output diaphragm assembly. Carefully guide the capillary tube into the small hole in the upper housing. Be certain the capillary is engaged in the hole before installing and tightening the clamping plate.
2. When assembling the diaphragm spacer to the input diaphragm assembly, align the small hole in the lower diaphragm (beam side of the assembly) to the hole in the spacer. The small hole in the upper diaphragm (range spring side of the assembly) does not line up with a hole.
3. Lubricate the two O-rings on the input diaphragm assembly. Slide the assembly into the upper housing so that the small hole in the lower diaphragm and spacer line up with the small hole in the upper housing.
4. Install the beam after the input and output diaphragm assemblies have been installed and securely tightened. Torque the two screws that hold the beam to the Output Diaphragm Assembly to 2.0-2.5 in. lbs. Set the height of the beam, per Figure 5-3, before locking the small jam nuts on the input diaphragm assembly (the  $3/32$ " dimension is a starting point and may have to be adjusted up or down if calibration cannot be achieved).
5. A complete calibration is required after assembly. This includes zero, span and output pressure level adjustments.



**FIGURE 5-3 Diaphragm and Beam Assembly**

## 5.3 PREVENTIVE

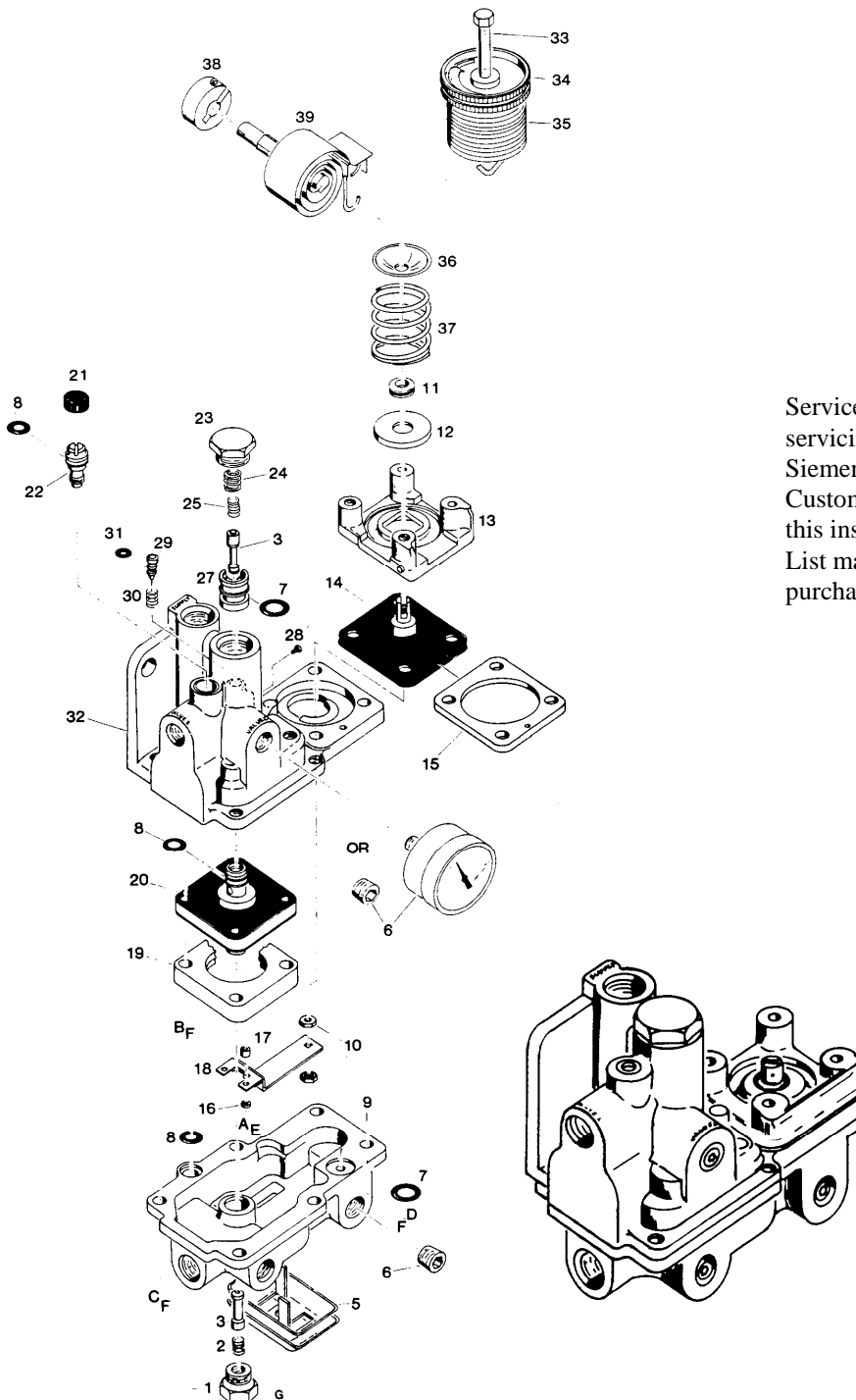
Most problems associated with pneumatic instruments can be avoided by the use of clean, dry, oil-free instrument air. Refer to Section 2.2 Instrument Air Requirements in this manual and to the Instrument Society of America's publication "Quality Standard for Instrument Air" (ISA-S7.3).

■

## 6.0 PARTS LIST

### Model Series 74 H/FR Valve Positioners

Drawing No. 12372PL  
11/94 Supersedes 1/88



#### IMPORTANT

Service Parts Kits are available for servicing the instrument. Contact Siemens for available kits; refer to the Customer/Product Support section of this instruction. Some parts in this Parts List may not be available for separate purchase.



<b>Symbol</b>	<b>Part No.</b>	<b>Description</b>	<b>Req'd</b>
*1	6751-3	Sealing Spring	1
*2	6750-49	Plunger Spring	1
*3	See Table	Plunger	2
5	12372-338	Exhaust Baffle	1
6a	3240-	Pipe Plug	See Table
6b	12444-1	0-30 psi Gauge (not shown)	See Table
6c	12444-2	0-160 psi Gauge	See Table
*7	See Table	O-Ring	2
*8	See Table	O-Ring	4
9	12372-152	Top Housing	1
10	12372-123	Nut	2
11	4951-16	Grommet (not used with item 37)	1
12	12372-108	Baffle (not used with item 37)	1
13	12372-112	Bottom Casting	1
*14	See Table	Diaphragm Assembly (Input)	1
15	12372-97	Diaphragm Ring	1
16	12372-138	Spacer	2
17	12372-51	Spacer	2
18	12372-126	Beam	1
19	See Table	Diaphragm Ring	1
*20	See Table	Diaphragm Ring (Output)	1
21	12372-378	Cap	1
22	12372-379	Adjusting Screw	1
*23	12372-109	Sealing Screw	1
*24	12372-130	Spring	1
*25	12372-111	Plunger Spring	1
27	12372-117	Plunger Seat	1
*28	10320-25	Screw	1
*29	12372-155	Cleaning Plunger	1
*30	10320-10	Plunger Spring	1
*31	See Table	O-Ring	1
32	See Table	Bottom Housing	1
33	12372-	Zero Screw (as specified on order)	1
34	12372-384	Range Spring Seat	2
35	14995-	Rectilinear Range Spring (as specified on order) (includes items 33 and 34)	1
36	12372-254	Spring Seat	1
37	12517-	Suppression Spring Kit (optional) (includes item 36)	1
38	9202-2	Split Clamp	1
39	14923-	Rotary Range Spring Kit (as specified on order) (Includes items 38, 40, and 41)	1

Symbol	Part No.	Description	Req'd
40	14923-52	Mounting Plate (not shown)	As Req'd
41	14923-49	Enclosure (not shown)	1
A	1-0265	2-56 x 1/4 Rd. Hd.	2
B	1-2565	10-32 x 7/8 Rd. Hd.	6
C	1-2450	10-32 x 9/16 Fill. Hd.	4
D	1-2550	10-32 x 7/8 Fill. Hd.	2
E	1-7216	#2 Med. Lwr.	2
F	1-7288	#10 Med. Lwr	12
G	1-1335	#6-32 x 1/2 Truss Hd.	1

\*Recommended On-Hand Spare Parts: Always specify range, serial number or other nameplate information when ordering spare parts.

Rebuild Kit 12372-413 (not for use with High Temperature option) includes items 2, 7, 8, 11, 14, 20, 24, 25, and 31.

#### Model Specific Part Numbers

ITEM						HIGH TEMPERATURE			
	G	N	SG	SN	SG-1	G	N	SG	SN
3	12372-107	12372-107	12372-351	12372-351	12372-107	12372-107	12372-107	12372-351	12372-351
6a	---	3	---	3	---	---	3	---	3
6b	1	---	1	---	1	1	---	1	---
6c	2	---	2	---	2	2	---	2	---
7	2938-3	2938-3	2938-3	2938-3	2938-3	2938-143	2938-143	2938-143	2938-143
8	2938-1	2938-1	2938-1	2938-1	2938-1	2938-140	2938-140	2938-140	2938-140
14	12372-116	12372-116	12372-116	12372-116	12372-116	14121-15	14121-15	14121-15	14121-15
19	12372-87	12372-87	14811-8	14811-8	14811-8	12372-87	12372-87	14811-8	14811-8
20	14811-45	14811-45	14811-45	14811-45	14811-45	14811-46	14811-46	14811-46	14811-46
31	2938-16	2938-16	2938-16	2938-16	2938-16	2938-144	2938-144	2938-144	2938-144
32	12372-159	12372-159	14811-9	14811-9	14811-9	12372-159	12372-159	14811-9	14811-9

