

FINE CONTROLS (UK) LTD



Fine Controls have been supplying process controls & instrumentation equipment since 1994, & now serves an ever expanding customer base, both in the UK & globally.

We offer a full range of valve & instrumentation products & services, with our product range representing leading technologies & brands:

Flow: Flow Meters & Transmitters, Flow Switches, Flow Control Valves & Batch Control Systems

Temperature: Temperature Probes & Thermowells, Temperature transmitters, Temperature Regulators & Temperature Displays

Level: Level Transmitters & Switches

Pressure: Pressure Gauges & Transmitters, Precision & High Pressure Regulators & I-P Converters, Volume boosters.

Precision Pneumatics: Pressure Regulators, I-P Converters, Volume Boosters, Vacuum Regulators

Valves: Solenoid & Pneumatic Valves, Control Valves & Positioners, Actuated Ball, Globe or Diaphragm Valves & Isolation Valves

Services: Repair, Calibration, Panel Build, System Design & Commissioning

A rotork® Brand
FAIRCHILD



bürkert



SIEMENS



alcon
SOLENOID VALVES

A rotork® Brand



MIDLAND-ACS
A rotork® Brand



Honeywell



Bourdon
Baumer Group



SOLDO
CONTROLS

A rotork® Brand



Fine Controls (UK) LTD, Bassendale Road, Croft Business Park,
Bromborough, Wirral, CH62 3QL UK
Tel: 0151 343 9966
Email: sales@finecontrols.com

Relays

Series 62 Constant-Differential Relays

Introduction

Features & Benefits

- ▶ The ability to maintain constant-differential pressure drop across a built-in needle valve ensures a constant volumetric flow rate
- ▶ Maintains constant bubbling rate in liquid level applications, eliminating the problems of typical conventional bubbling systems
- ▶ The ability to produce reasonable purge rates eliminates the need for a supply regulator
- ▶ Epoxy powder coating provides improved corrosion resistance

Description

4

The Series 62 Constant-Differential Relays serve as air-flow controllers maintaining a constant air purge for each setting of an integral needle valve.

By maintaining a constant-differential pressure drop across a built-in needle valve (for any flow setting up to 2.1 cu. ft. of air per hour), Series 62 Relays ensure a constant volumetric rate of flow, regardless of variations in process or supply pressure.

The constant-differential pressure across the built-in needle valve is regulated by a spring-loaded diaphragm. This diaphragm controls the action of the supply-port plunger, which automatically admits supply air to the needle valve at the required rate. Excess purge air bleeds to the atmosphere.

Siemens constant-differential relays eliminate most of the problems encountered in conventional bubbling systems, because:

- ▶ Each relay holds the bubbling rate constant, thereby maintaining high measurement accuracy
- ▶ The differential pressure maintained across the needle valve is approximately 1-1/2 psi, which allows wider needle valve openings that are less subject to clogging
- ▶ Full supply pressure (up to 150 psig) is connected to the purge system for a greater margin of safety
- ▶ Ordinary air-line impurities have no effect

In addition to the preceding advantages, the Series 62 Constant-Differential Relays ensure reasonable purge rates at all times, because they eliminate the need for a supply regulator. Another safety feature is the automatic exhaust, which bleeds off any excess air caused by the presence of foreign particles on the pilot seat of the supply-port plunger.



Specifications

Supply Pressure

Maximum: 150 psig
Minimum: 5 psi above highest output pressure required

Rotometer Pressure

Maximum: 200 psig (1380 kPa)

Supply Pressure Effect

0.18 scfh (max.) flow change for 25 psi increase of supply

Ambient Temperature Limits

-40 to 180°F (-40 to 82°C)
-40 to 160°F (-40 to 71°C) with Rotometer

Materials of Construction

Relay: Aluminum, brass, stainless steel, Neoprene, Buna-N
Rotometer: Aluminum, Stainless steel, Borosilicate glass, Buna-N (O-rings), ruby sapphire (float), and brass (fittings)

Relays

Series 62 Constant-Differential Relays

Ordering data

Model Number

Constant-Differential Relay

Purge Rate

- 0.09 to 2.1 scfh¹
Built-in needle valve has internal bypass to prevent tight shut-off of purge flow
- 0.06 to 1.8 scfh¹
Built-in needle valve provides tight shut-off of purge flow

Flow Indicator²

- Indicating Rotometer
0.25 to 2.5 scfh scale range
Letter omitted - Less Rotometer

Order No.

62-

■ ■

↑ ↑

V

VN

A

Mounting Dimensions

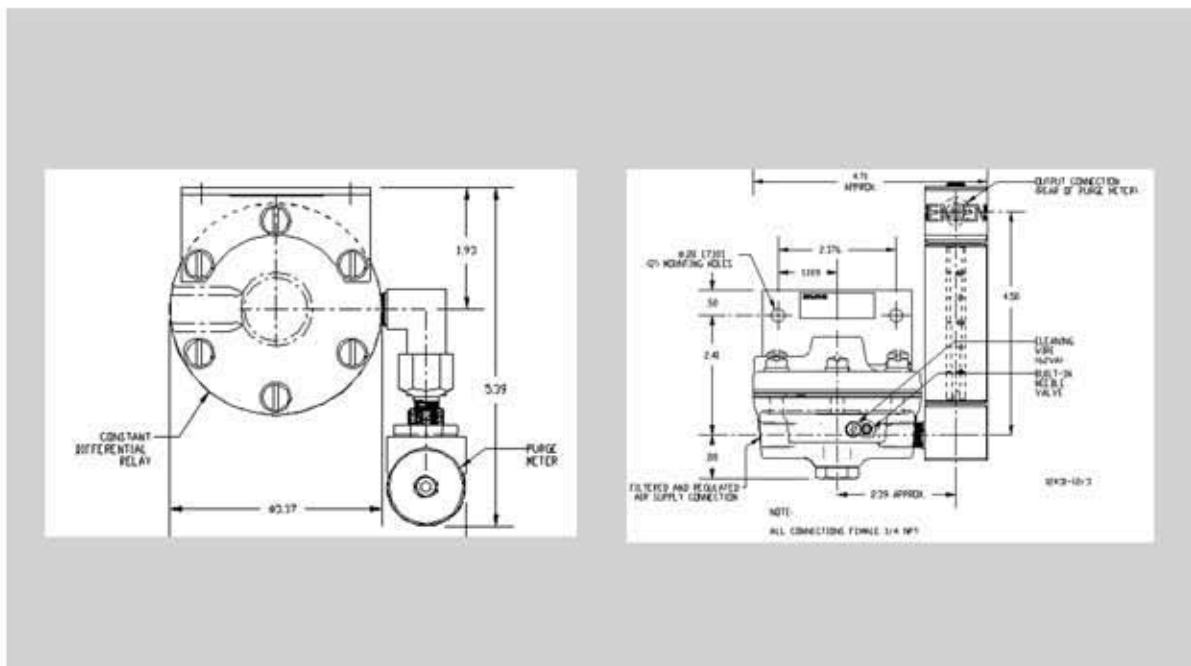

1) With a relay or rotometer outlet at atmospheric pressure.
2) A flow indicator is recommended for use with the Model 62VN.