

FINE CONTROLS (UK) LTD



Fine Controls have been supplying process controls & instrumentation equipment since 1994, & now serves an ever expanding customer base, both in the UK & globally.

We offer a full range of valve & instrumentation products & services, with our product range representing leading technologies & brands:

Flow: Flow Meters & Transmitters, Flow Switches, Flow Control Valves & Batch Control Systems

Temperature: Temperature Probes & Thermowells, Temperature transmitters, Temperature Regulators & Temperature Displays

Level: Level Transmitters & Switches

Pressure: Pressure Gauges & Transmitters, Precision & High Pressure Regulators & I-P Converters, Volume boosters.

Precision Pneumatics: Pressure Regulators, I-P Converters, Volume Boosters, Vacuum Regulators

Valves: Solenoid & Pneumatic Valves, Control Valves & Positioners, Actuated Ball, Globe or Diaphragm Valves & Isolation Valves

Services: Repair, Calibration, Panel Build, System Design & Commissioning

A rotork® Brand
FAIRCHILD



bürkert



SIEMENS



alcon
SOLENOID VALVES

A rotork® Brand



MIDLAND-ACS
A rotork® Brand



Honeywell



Bourdon
Baumer Group



SOLDO
CONTROLS

A rotork® Brand



Fine Controls (UK) LTD, Bassendale Road, Croft Business Park,
Bromborough, Wirral, CH62 3QL UK
Tel: 0151 343 9966
Email: sales@finecontrols.com



Severe & Hazardous Area Experts

INTRODUCTION

From the day the company was founded in 1956 it was decided that our business should be built on the premise of creating solutions that far outweigh expectations. Over recent years users of Regulators and Filter Regulators have become aware of the consequences of the failure in service of such equipment including the potential for damage to pressure sensitive instruments, actuators and process valves which may compromise critical ESD systems, resulting in unscheduled production shut-downs and expensive repairs.

We have always had a strong, experienced and knowledgeable team of people working within the company and it's thanks to them, their capabilities and solutions that we have now extended the 3550 Series Air Preparation Equipment range to include the option of our **Over Pressurisation Device (OPD)**.

The OPD is available in a selection of pressure ranges to suit different applications and can be ordered with the regulator and trip pressures preset & tagged by the factory if required. The options for the 3550 Series pneumatic range apply, including 1/4" and 1/2" interface connections and low temperature (-50°C) options. Please see the pneumatic products catalogue for further information.



CERTIFICATION OPTIONS AVAILABLE

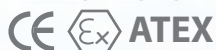

www.midland-acs.com

OVER PRESSURIZATION DEVICE (OPD) STEMSAVER



- *Specifically designed for Severe Offshore Environments*
- *Functional safety data available upon request*
 - *1/4" and 1/2" connection sizes*
 - *Auto shut-off*
 - *Easy Installation*
- *Ambient Temperature Range -20°C to +80°C*
(Low temperature version -50°C)
- *316 Stainless Steel Construction*
- *Protection of equipment from regulator failure & over pressure events*

General Description

The purpose of the OPD "STEMSAVER" is to protect downstream equipment from over pressure events including regulator failure, thus preventing potential damage and downtime. Applications include the protection of ESD & safety instrumented systems including positioners, actuators and process valve stems. The device includes an integral 3550 series pressure regulator with a protection valve and sensor system built into a common body.

Increases in outlet pressure can occur for many reasons, including failure of key regulator components. Should this occur the device will automatically fail-safe within 30 milli-seconds*. The integral valve will be triggered to shut-off the outlet and either vent the downstream pressure or trap & lock at the secondary preset trip pressure level. The mode of operation can be selected by leaving the exhaust port of the valve open or plugged.

When the integral valve has deployed, the reset button protrudes from the housing providing a positive indication that a fault has occurred; models are also available with air pilot operators or proximity switches to indicate the triggered position. The OPD reduces the potential for damage occurring from increased torque, thrust or pressure values within the downstream system. Once the fault has been corrected the unit can be reset by pushing the reset button on the unit. In line with today's requirements for space saving, weight reduction and efficiency the system is all close coupled within a compact body.

*Time stated for 4-8 bar variant; please see specification for further information regarding lower pressure versions.

OVER PRESSURIZATION DEVICE (OPD) STEMSAVER

Development

Failures of pressure regulators can result in the over pressurisation of the downstream line, as the self-relieving capacity of the regulator is insufficient to cope with major failures. Usually a relief valve of sufficient capacity is fitted into the system to hold the pressure down to an acceptable level.

However a relief valve flow is sized on a pressure differential between set pressure and over pressure, usually 10%. Thus on a set pressure of 4.5 barg a pressure rise to 4.95 barg would have to flow sufficiently to hold the pressure at 4.95 barg, against the flow through a failed pressure regulator. At 10 barg supply pressure the flow through the failed pressure regulators will be driven by a 10 to 4.95 i.e. 5.05 barg pressure drop. In many cases this would result in damage to sensitive & expensive equipment such as positioners, actuator diaphragms and process valve stems. An alternative is to fit an excessively large relief valve(s), which in itself could cause serious problems by dumping all of the systems air and starving other equipment resulting in plant shutdown.

Considered Regulator Failure modes

Failure modes are common to all manufacturers' regulators unless specific design changes have been made to cope with them. Therefore to overcome these difficulties the OPD "STEMSAVER" was designed and engineered.

Typical Regulator Failure Modes

- Misuse and maladjustment during installation and commissioning.
- Rupture of diaphragm leading to total loss of pressure regulation.
- Failure of regulator seat leading to partial or total loss of pressure regulation.
- Blocking of the regulator relief port leading to total loss of pressure regulation.

OVER PRESSURIZATION DEVICE (OPD) STEMSAVER

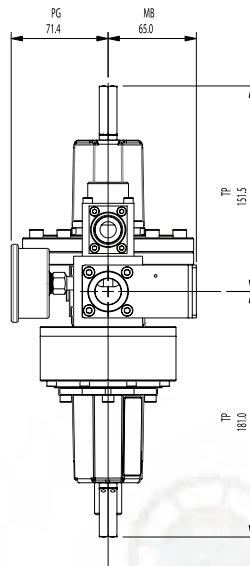
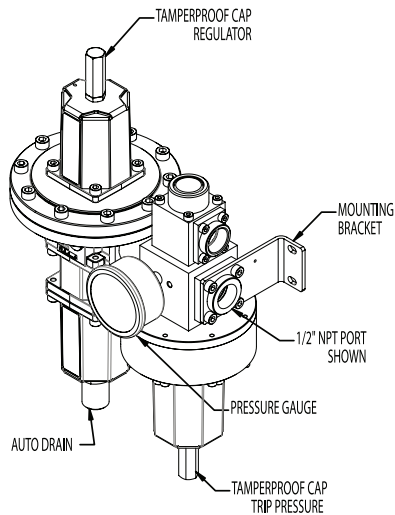

0.5 - 2 Bar Variant

Key

- MB - Dimensions for model with mounting bracket option
- PG - Dimensions for model with pressure gauge option
- TP - Dimensions for model with tamperproof cap option
- OPD - Dimensions for Manual Drain Version
- OPA - Dimensions for Automatic Drain Version

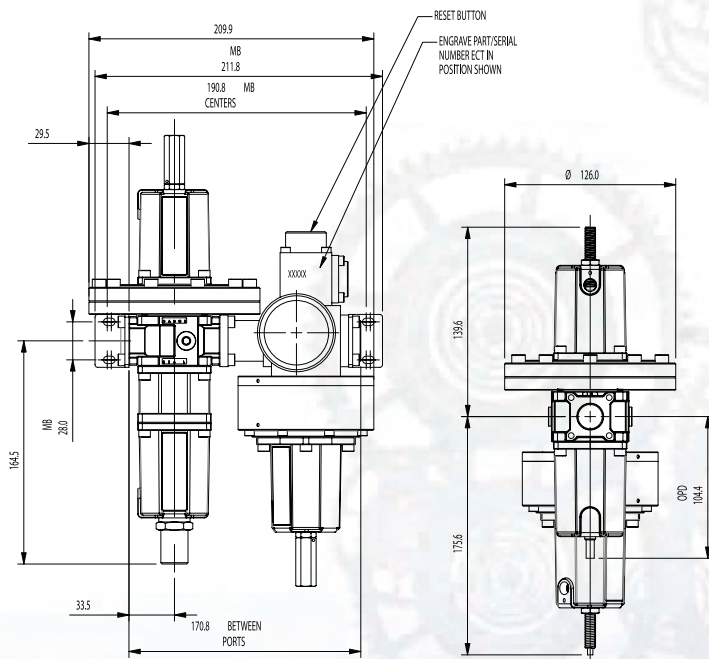

Maximum Response Time

- 150ms

Trip Pressure Range

- 1 - 2.5 bar

Temperature Range

- Standard: -20°C to +80°C (-4°F to +176°F)
- Low Temp: -50°C (-58°F) (optional)

Maximum Inlet Pressure

- Manual drain: 20 bar
- Auto drain: 17 bar

Regulated Outlet Pressure

- 0.5 - 2 bar

Safety Function Statement:

To regulate, filter and provide overpressure protection of air supplied to a downstream actuator & associated equipment. Functional safety data available on request (3rd party approved for 4-8bar variant).

OVER PRESSURIZATION DEVICE (OPD) STEMSAVER

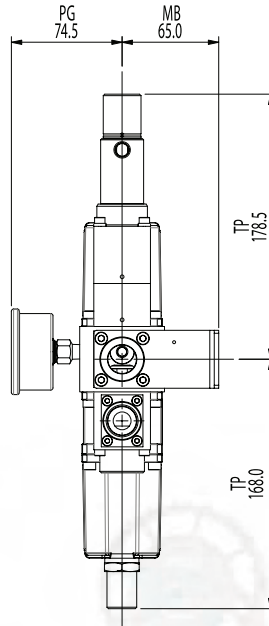
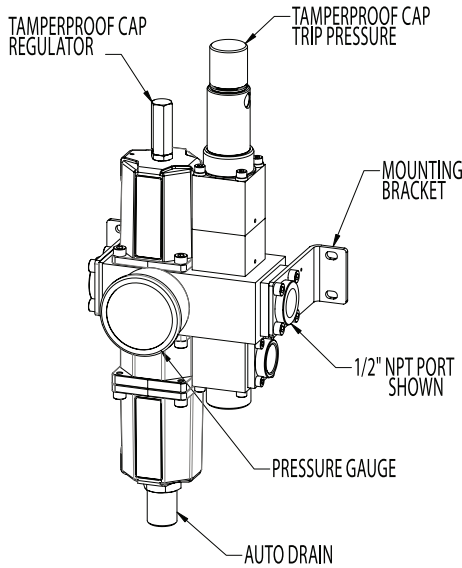

2 - 4 Bar Variant

Key

- MB - Dimensions for model with mounting bracket option
- PG - Dimensions for model with pressure gauge option
- TP - Dimensions for model with tamperproof cap option
- OPD - Dimensions for Manual Drain Version
- OPA - Dimensions for Automatic Drain Version

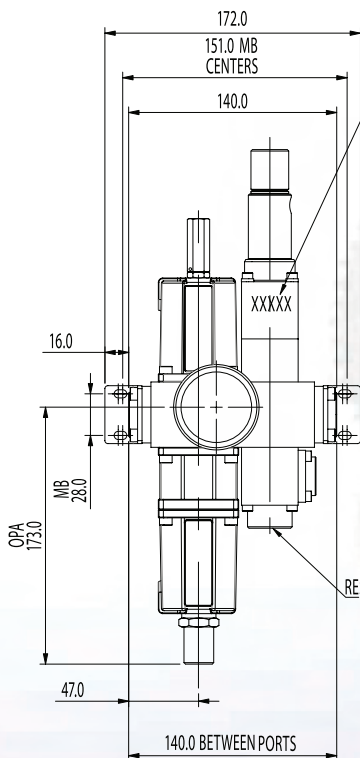

ENGRAVE PART/SERIAL NUMBER ECT IN POSITION SHOWN

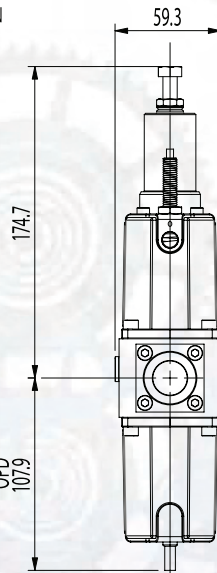

Maximum Response Time

- 90ms

Trip Pressure Range

- 2.5 - 4.5 bar

Temperature Range

- Standard: -20°C to +80°C (-4°F to +176°F)
- Low Temp: -50°C (-58°F) (optional)

Maximum Inlet Pressure

- Manual drain: 20 bar
- Auto drain: 17 bar

Regulated Outlet Pressure

- 2 - 4 bar

Safety Function Statement:

To regulate, filter and provide overpressure protection of air supplied to a downstream actuator & associated equipment.

Functional safety data available on request (3rd party approved for 4-8bar variant).

OVER PRESSURIZATION DEVICE (OPD) STEMSAVER

4 - 8 Bar Variant

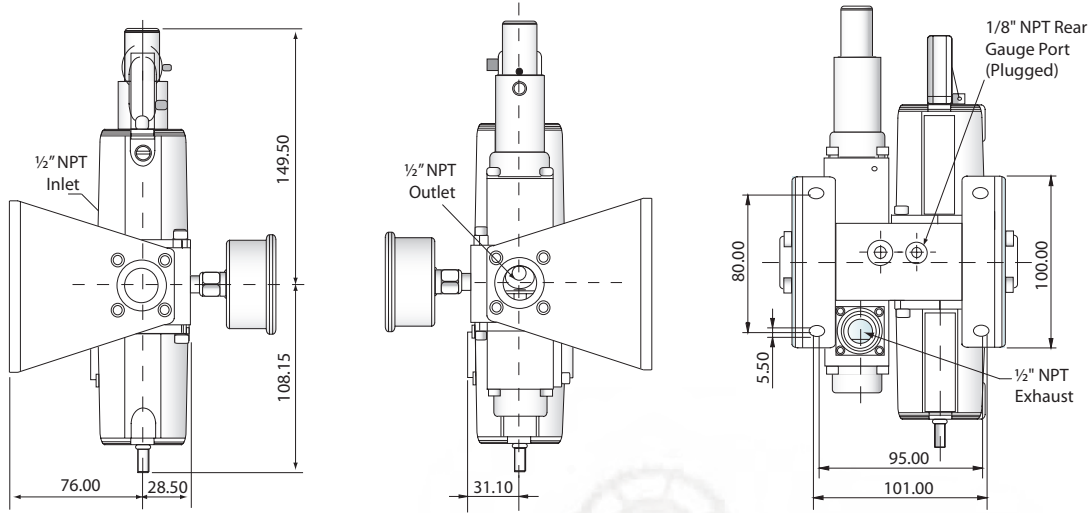

Mounting bracket and gauge option shown

Maximum Response Time

- 30ms

Trip Pressure Range

- 4.5 - 8.5 bar

Temperature Range

- Standard: -20°C to +80°C (-4°F to +176°F)
- Low Temp: -50°C (-58°F) (optional)

Maximum Inlet Pressure

- Manual drain: 20 bar
- Auto drain: 17 bar

Regulated Outlet Pressure

- 4 - 8 bar

Safety Function Statement:

To regulate, filter and provide overpressure protection of air supplied to a downstream actuator & associated equipment.

Functional safety data available on request (3rd party approved for 4-8bar variant).

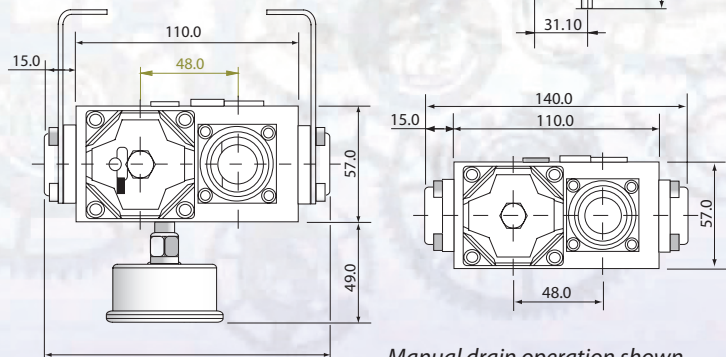
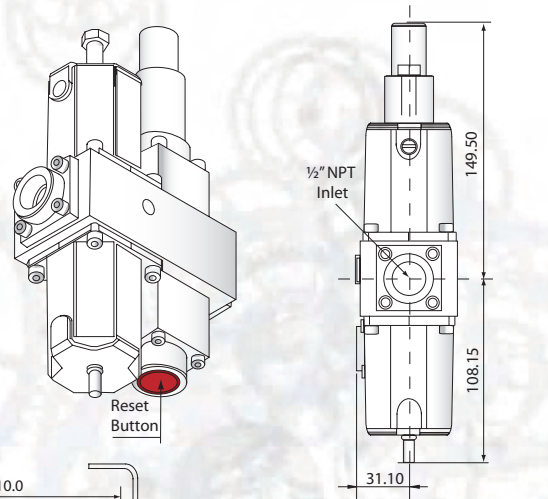

Manual drain operation shown
Automatic drain option available

OVER PRESSURIZATION DEVICE (OPD) STEMSAVER

Ordering Information

										2 = ¼" 4 = ½"	VALVE SIZE
										OPD = Manual Drain OPA = Automatic Drain	TYPE
										S = Stainless Steel 316	MATERIAL
										V = Viton F = Fluorosilicon (Low Temp)	SEALS
										2 = 2 Bar 4 = 4 Bar 8 = 8 Bar	PRV PRESSURE
										1 = BSPP 2 = NPT	PORT STYLE
										2 = 2/2 3 = 3/2	FUNCTION
										49 = 4.9 bar 62 = 6.2 bar XX = Unset	SECONDARY PRESSURE USE 2 DIGITS TO SPECIFY SET PRESSURE (MUST BE WITHIN PRV PRESSURE RANGE)
										54 = 54 bar 67 = 6.7 bar XX = Unset	TRIP PRESSURE USE 2 DIGITS TO SPECIFY SET PRESSURE. MUST BE AT LEAST 0.5 BAR ABOVE SECONDARY PRESSURE BUT NOT MORE THAN 0.5 BAR THE MAX PRV PRESSURE RANGE FOR THE VARIANT
										TP = Tamper proof cap MB = Mounting brackets PG = Pressure gauge	SPECIAL FEATURES
4	OPD	S	V	2	2	3	49	XX	TP	Example	