

FINE CONTROLS (UK) LTD



Fine Controls have been supplying process controls & instrumentation equipment since 1994, & now serves an ever expanding customer base, both in the UK & globally.

We offer a full range of valve & instrumentation products & services, with our product range representing leading technologies & brands:

Flow: Flow Meters & Transmitters, Flow Switches, Flow Control Valves & Batch Control Systems

Temperature: Temperature Probes & Thermowells, Temperature transmitters, Temperature Regulators & Temperature Displays

Level: Level Transmitters & Switches

Pressure: Pressure Gauges & Transmitters, Precision & High Pressure Regulators & I-P Converters, Volume boosters.

Precision Pneumatics: Pressure Regulators, I-P Converters, Volume Boosters, Vacuum Regulators

Valves: Solenoid & Pneumatic Valves, Control Valves & Positioners, Actuated Ball, Globe or Diaphragm Valves & Isolation Valves

Services: Repair, Calibration, Panel Build, System Design & Commissioning

A rotork® Brand
FAIRCHILD



bürkert



SIEMENS



alcon
SOLENOID VALVES

A rotork® Brand



MIDLAND-ACS
A rotork® Brand



Honeywell



Bourdon
Baumer Group



SOLDO
CONTROLS

A rotork® Brand



Fine Controls (UK) LTD, Bassendale Road, Croft Business Park,
Bromborough, Wirral, CH62 3QL UK
Tel: 0151 343 9966
Email: sales@finecontrols.com

FAIRCHILD MODEL T5700 ELECTRO-PNEUMATIC TRANSDUCER

Installation, Operation and Maintenance Instructions

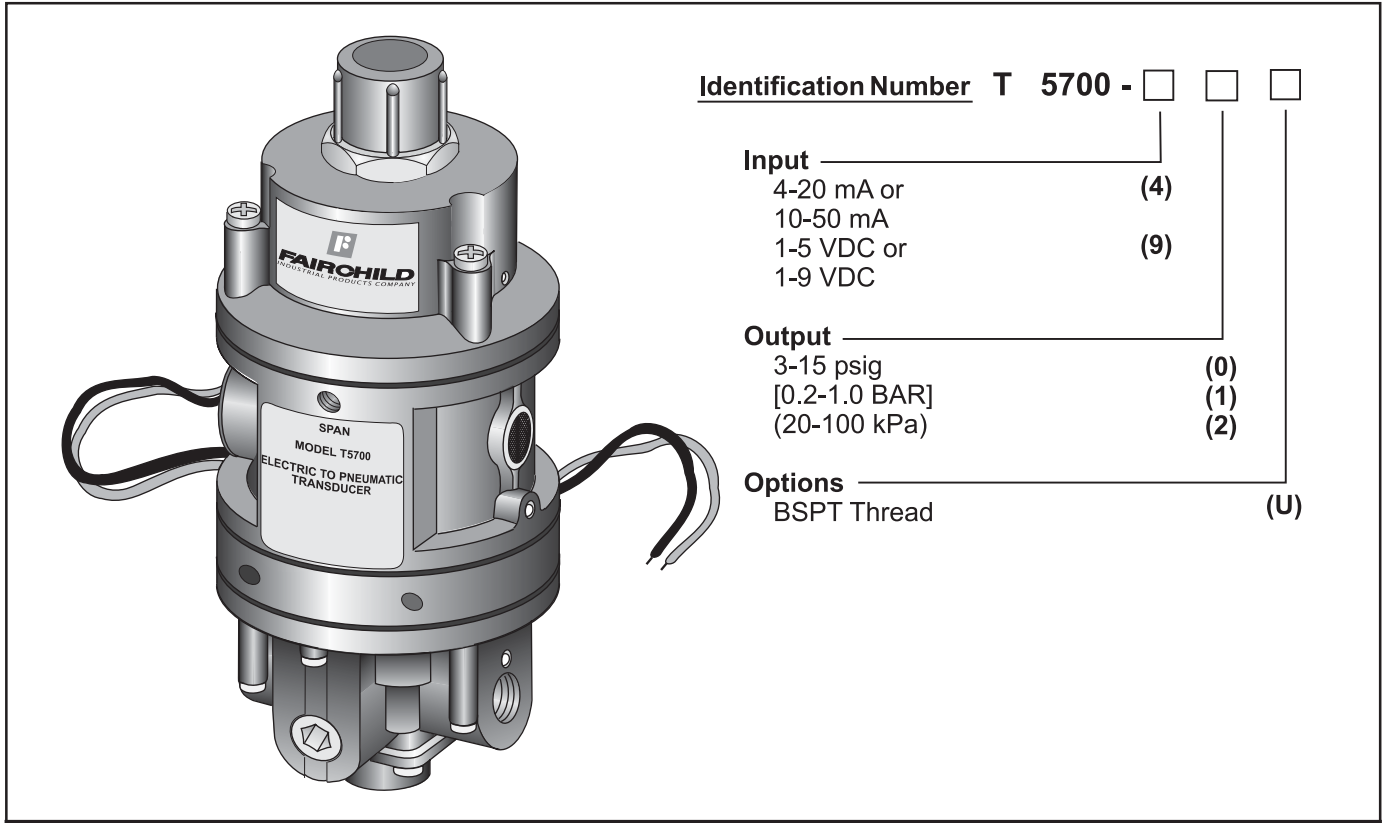

Figure 1. Model T5700 Transducer Identification Number System.

GENERAL INFORMATION

The Model T5700 is an electro-pneumatic device that converts a current or voltage signal to a linear pneumatic output.

SPECIFICATIONS

Functional Specifications	
Output Range	3-15 psig [0.2-1.0 BAR] (20-1000 kPa)
Supply Pressure	18-150 psig [1.2-10 BAR] (120-1000 kPa)
Maximum Output Capacity (SCFM)	17 (28.9 m ³ /HR) for 20 psig, [1.4 BAR], (140 kPa) supply. 47 (79.9 m ³ /HR) for 120 psig, [8.0 BAR], (800 kPa) supply.
Exhaust Capacity (SCFM)	over 9 (15.3 m ³ /HR) downstream pressure 5 psig, [0.35 BAR], (35 kPa) above set point.
Maximum Air Consumption (SCFM)	0.05 (.08 m ³ /HR) dead ended with 20-120 psig, [1.5-8.0 BAR], (150-800 kPa) supply.

Specifications (continued)

Impedance/ Input Signal	Input Range	OHMS
	4-20 mA	62
	10-50 mA	26
	1-5 VDC	510
	1-9 VDC	1020
Temperature Range	-40° F to +150° F (-40° C to +65° C)	
Temperature Coefficient	<1% of span/50° F (28° C) Change.	
Performance Specifications		
Terminal Based Linearity	± 1.0% Full Scale	
Independent Linearity	± 0.5% Full Scale	
Supply Pressure Effect	± 0.3% Full Scale for ± 50 psig, [3.5 BAR], (350 kPa) change.	
Hysteresis & Repeatability	Within 0.1% Full Scale	
Materials of Construction	Housing..... Aluminum Orifice..... Sapphire Nozzle..... Bronze Diaphragm..... Buna N on Dacron Fabric	

INSTALLATION

The Model T5700 is supplied with a Mounting Kit 15396 for Panel/Wall Mounting or 1 1/2" Pipe Mounting. For more information, see Figure 3. below.

Pneumatic Connections

Clean all pipelines to remove dirt and scale before installation.

Apply a minimum amount of pipe compound to the male threads of the fitting only. **Do Not use teflon tape as a sealant.** Start with the third thread back and work away from the end of the fitting to avoid the possibility of contaminating the transducer. Install the transducer in the air line.

The inlet and outlet connections are labeled on the underside of the regulator with the arrows pointing in the direction of the flow. Tighten connections securely. Avoid under-sized fittings that will limit the flow through the transducer and cause a pressure drop downstream. For more information, see Figure 2 "Outline Drawing" below.

NOTE: Instrument air is not required. If an air line lubricator is used, it MUST be located downstream, beyond the transducer.

Electric Connections

Make connections to the Red and Black wires as shown in Figure 4. "Calibration Configuration" on page 3.

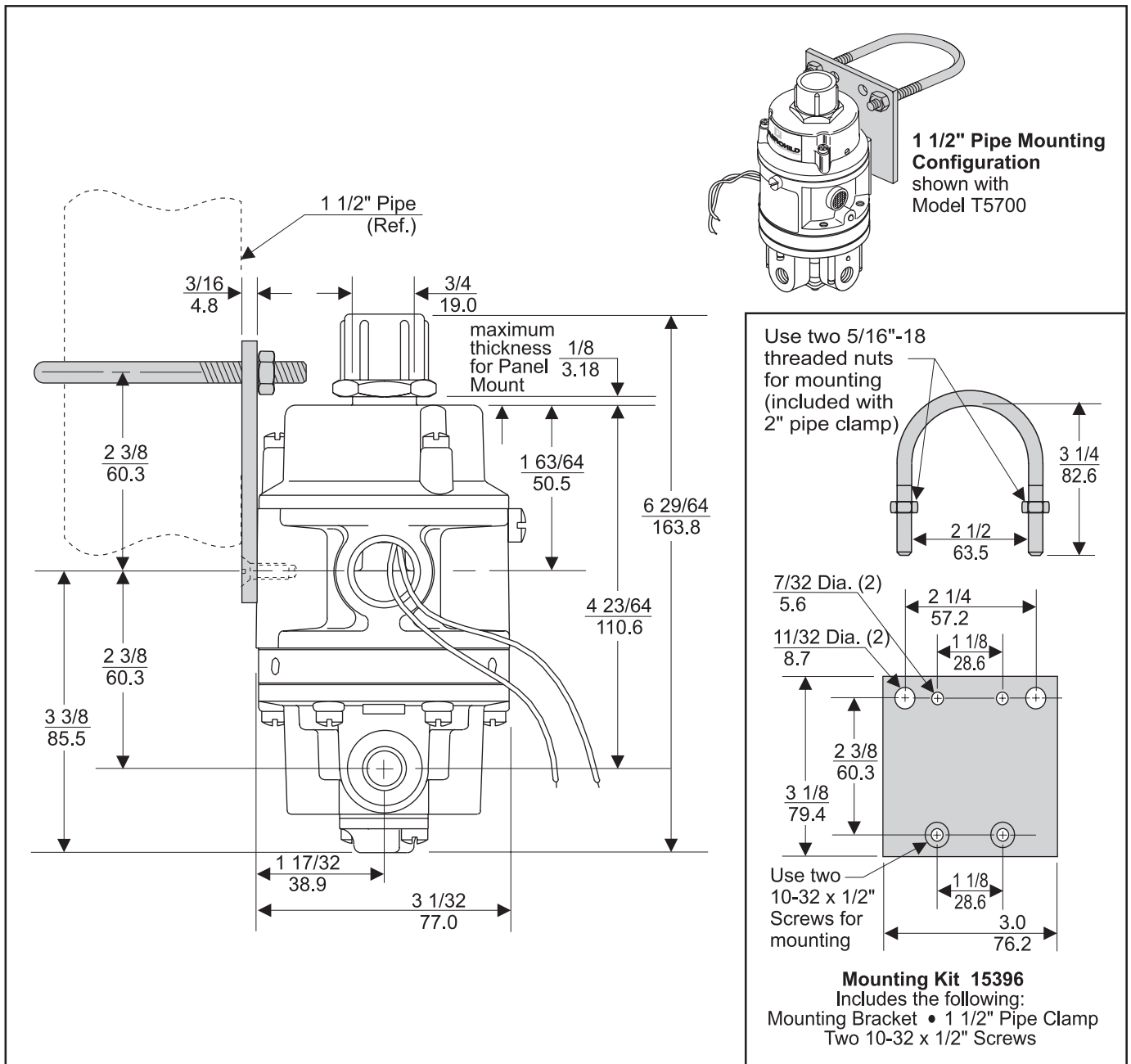

Figure 2. Outline Dimensions.

Figure 3. Mounting Kit 15396. (Included with Unit)

CALIBRATIONS / ADJUSTMENTS

Equipment Required for Calibration:

- Pneumatic Supply capable of delivering up to 150 psig.
- Current Supply capable of delivering up to 50 mA.
- Voltage Supply capable of delivering up to 10 volts.
- Pressure Gage capable of a digital readout up to 50 psig with an accuracy of .1%.
- Digital Volt Meter capable of a readout up to 30 mA or 10 volts with an accuracy of .02%.

NOTE: The transducer is factory calibrated in the vertical position. Before you do the final calibration, place the unit in a position that is the same as the actual operating position.

FULL RANGE OPERATION

NOTE: Air Supply must be connected before adjustments are made.

Forward Acting Mode Adjustment

- Forward Acting Calibration - Zero

NOTE: Remove cap over zero screw.

1. Apply the minimum input signal and adjust the Zero screw for minimum output pressure.

Forward Acting Mode Adjustment (continued)

- Forward Acting Calibration - Span

NOTE: Remove plastic screw from span adjust hole.

2. Apply the maximum input signal and adjust the Span screw for maximum output pressure.
3. Repeat steps 1-2 until the desired output range is obtained.

Reverse Acting Mode Adjustment

NOTE: Reverse the red and black input leads.

- Reverse Acting Calibration - Zero

NOTE: Remove cap over zero screw.

4. Apply the minimum input signal and adjust the Zero screw for maximum output pressure.

- Reverse Acting Calibration - Span

NOTE: Remove plastic screw from span adjust hole.

5. Apply the maximum input signal and adjust the Span screw for minimum output pressure.
6. Repeat steps 4-5 until the desired output range is obtained.

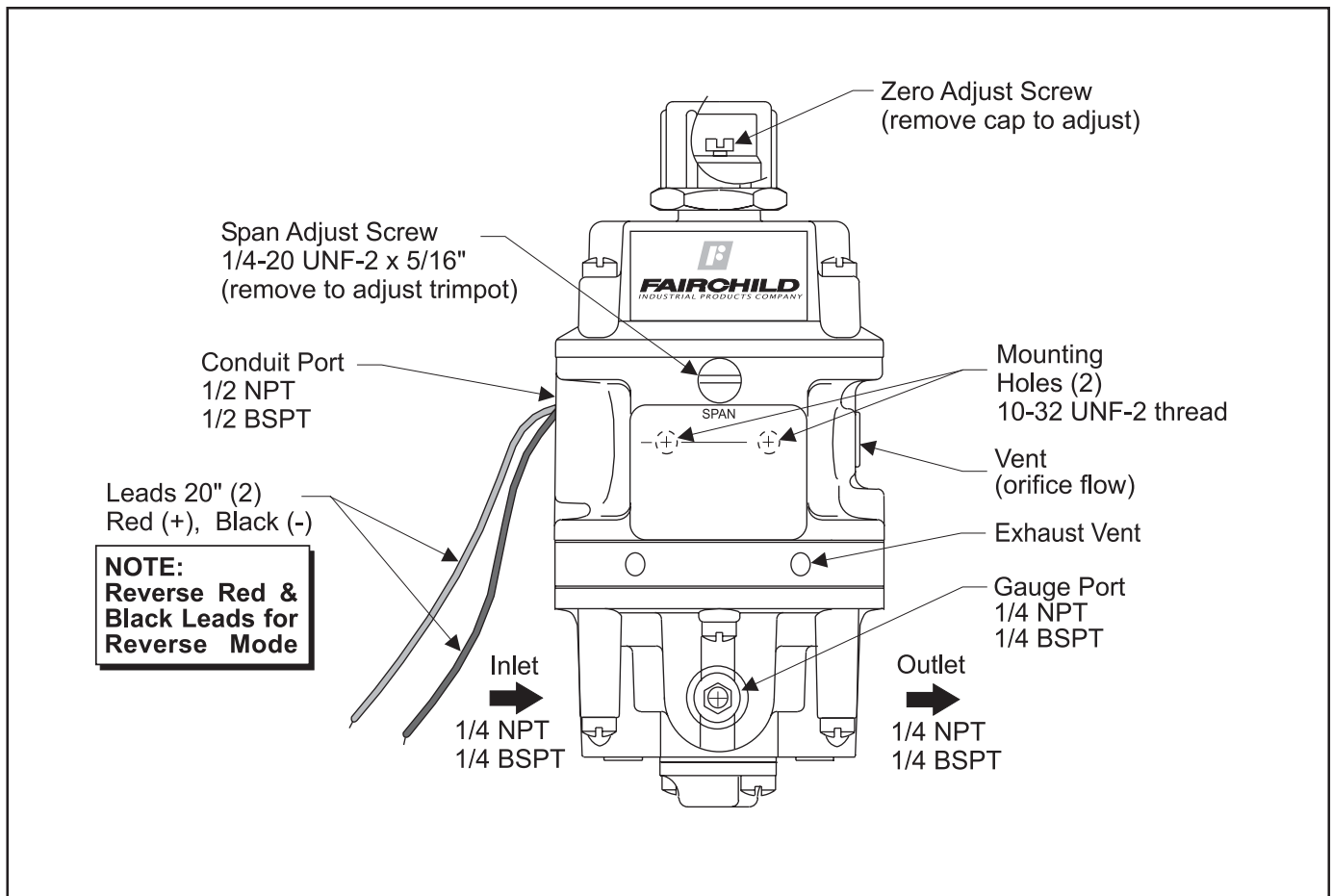

Figure 4. Calibration Configuration

Table 1. T5700 Transducer Components.

Item	Qty.	Description
1	1	Cover, Machining
2	3	Screw
3	1	Intermediate Housing
4	1	Spring
5 ¹	1	Diaphragm Assembly
6	1	Spacer Ring
7	1	Orifice
8	4	Screw
9	1	Seal Plate Assembly
10 ¹	1	Seal Plate Gasket
11	1	Body Assembly
12	4	Screw
13	2	Screw
14 ¹	1	Seat Ring Assembly
15 ¹	1	Screen
16 ¹	1	Inner Valve Assembly
17	1	Retainer Plate
18	1	Retainer Cap
19	2	Screw

¹ 19453-1 Service Kit Components.
3-15 psig, [0.2-1.0 BAR], (20-100 kPa)

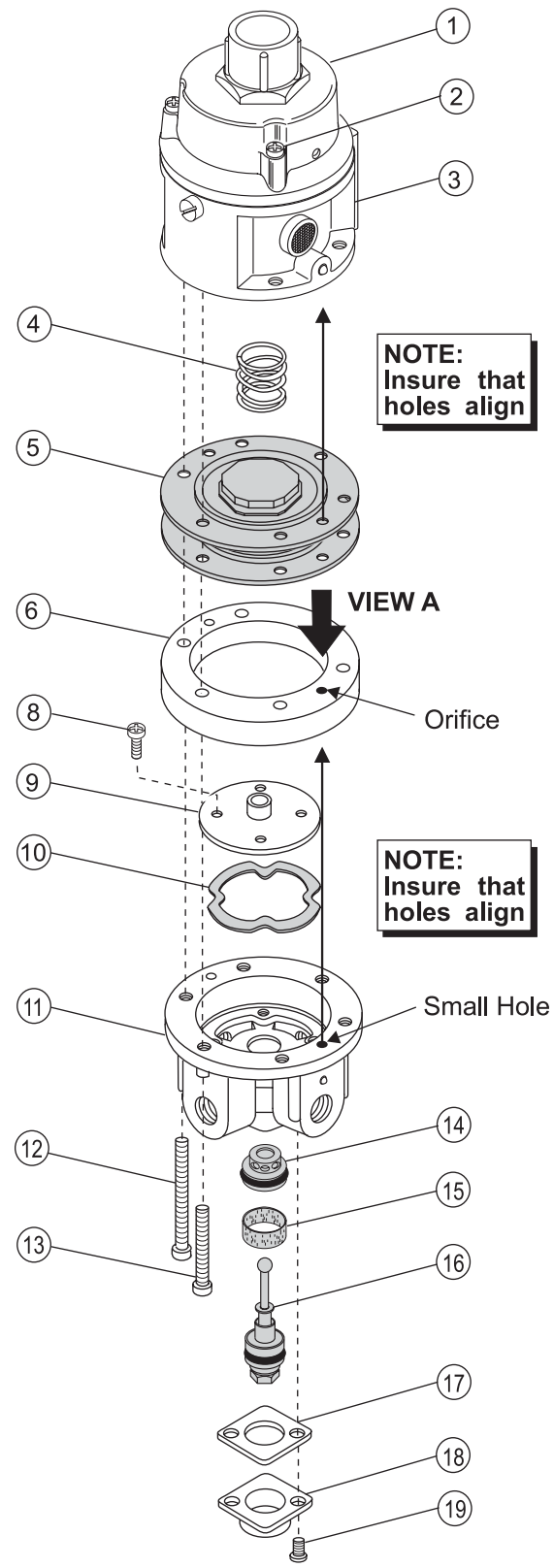
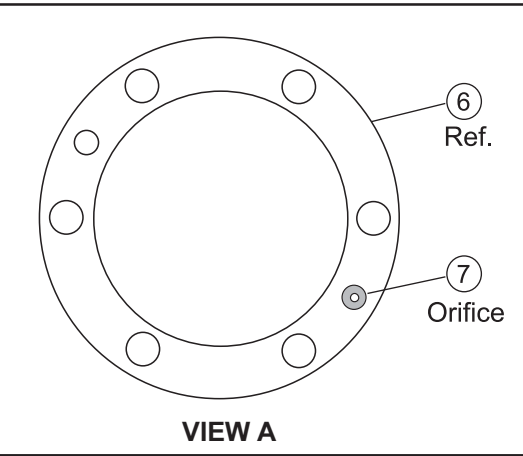

Figure 5. Exploded Drawing.

MAINTENANCE

To clean the Orifice, use the following procedure:

1. Shut off the valve that is supplying air to transducer. **It is not necessary to remove the Transducer from the air line.**
2. Remove six screws (12) & (13) holding the Spacer Ring (6) to the Body Assembly (11). For more detailed information see Figure 5. "Exploded Drawing" on page 4.
3. Blow out the Orifice (7) with compressed air.

NOTE: If the standard maintenance procedure does not correct the problem, install service kit.

TROUBLE-SHOOTING

Table 2. Trouble-Shooting.	
Problem	Solution (check)
No Output	Supply Pressure Clogged Orifice
Leakage	Connections
Improper Span Adjust	Zero and Span Adjust Output Leakage
Erratic Operation	DC Signal Loose Wires or Connections Liquid in Air Supply Dirt in Magnet Gap

Legal Notice

The information set forth in the foregoing Operation and Maintenance Instructions shall not be modified or amended in any respect without prior written consent of Fairchild Industrial Products Company. In addition, the information set forth herein shall be furnished with each product sold incorporating Fairchild's unit as a component thereof.



ISO 9001:2000
FM NO. 25571

*ISO 9001:2000
Certified*



Fairchild Industrial Products Company
3920 West Point Blvd . • Winston-Salem, NC 27103
phone: (336) 659-3400 • fax: (336) 659-9323
sales@fairchildproducts.com • www.fairchildproducts.com

IS-500T5700
Litho in USA
Rev. O 08/05