

# FINE CONTROLS (UK) LTD



Fine Controls have been supplying process controls & instrumentation equipment since 1994, & now serves an ever expanding customer base, both in the UK & globally.

We offer a full range of valve & instrumentation products & services, with our product range representing leading technologies & brands:

**Flow:** Flow Meters & Transmitters, Flow Switches, Flow Control Valves & Batch Control Systems

**Temperature:** Temperature Probes & Thermowells, Temperature transmitters, Temperature Regulators & Temperature Displays

**Level:** Level Transmitters & Switches

**Pressure:** Pressure Gauges & Transmitters, Precision & High Pressure Regulators & I-P Converters, Volume boosters.

**Precision Pneumatics:** Pressure Regulators, I-P Converters, Volume Boosters, Vacuum Regulators

**Valves:** Solenoid & Pneumatic Valves, Control Valves & Positioners, Actuated Ball, Globe or Diaphragm Valves & Isolation Valves

**Services:** Repair, Calibration, Panel Build, System Design & Commissioning

A rotork® Brand  
**FAIRCHILD**



**bürkert**



**SIEMENS**



**alcon**  
SOLENOID VALVES

A rotork® Brand



**MIDLAND-ACS**  
A rotork® Brand



**Honeywell**



**Bourdon**  
Baumer Group



**SOLDO**  
CONTROLS

A rotork® Brand



Fine Controls (UK) LTD, Bassendale Road, Croft Business Park,  
Bromborough, Wirral, CH62 3QL UK  
Tel: 0151 343 9966  
Email: sales@finecontrols.com

## Remote Process Actuation Control System AirLINE – PHOENIX INLINE

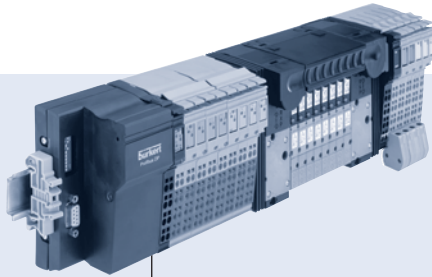

Type 8644 can be combined with...

- Fully compatible with Phoenix Inline System
- Combination of Fieldbus, pilot valves and I/O modules
- High flexibility
- Compact design
- High flow rate



**Type 8175**  
Sensors

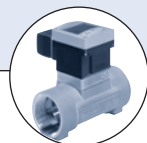

**Type 8032**  
Switches

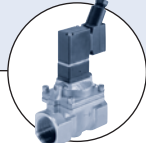

**Type 6212**  
Solenoid valves

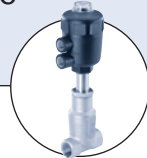

**Type 2012**  
Process valves

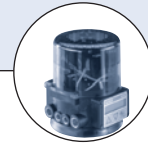

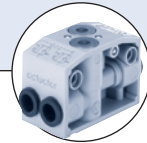

**Type 8630**  
Valve controllers





**Type 0498**  
Double pilot controlled check valve

The AirLINE System integrates high performance solenoid pilot valves, remote electronic I/O and fieldbus communication into a process actuation and control system that is both compact and extremely flexible. Its modular design allows fully customized, pre-mounted and tested solutions to exactly

meet all application needs including the integration of a local Mini PLC. Due to the full electronic and mechanical integration, the valve block can be added without the need of any tools or wiring.

Specifications	Pilot valve type	
	0460, 6524, 6525 	0461, 6526, 6527 
<b>Mounting dimensions</b>	11 mm	16.5 mm
<b>Circuit functions/ways</b>	C (3/2) D (3/2) H (5/2) H (5/2) impulse L (5/3) in middle position all ports closed N (5/3) in middle position all ports vented	C (3/2) D (3/2) H (5/2) H (5/2) impulse L (5/3) in middle position all ports open N (5/3) in middle position all ports vented
<b>Flow rate</b>	300 l/min (200 l/min for functions H impulse, L and N)	700 l/min (500 l/min for functions H impulse, L and N)
<b>Pressure range</b>	Vac. up to 10 bar	Vac. up to 10 bar
<b>Module types</b>	2x and 8x (optional integrated check valves and p-shut-off-valve)	2x and 4x (optional integrated check valves) Combination of 11 mm modules (3 valves) and 16.5 mm modules is possible
<b>Max. number of modules</b>	Depending on application	Depending on application
<b>Max. number of valves functionalities</b>	64 (by use of Type 0460 & Type 6524 2 x 3/2-way valve: 32)	32 (by use of Type 0461: 24)
<b>Pneumatic intermediate supply module</b>	necessary after 24 valve functions; with 2 x 3/2-way valve: necessary after 16 valve functions	necessary after 16 valve functions

to be continued on page 2

Specifications	Pilot valve type	
	0460, 6524, 6525 	0461, 6526, 6527 
<b>Fieldbus type</b>	PROFIBUS DP, INTERBUS, DeviceNet, CANopen, Ethernet, others on request	PROFIBUS DP, INTERBUS, DeviceNet, CANopen, Ethernet, others on request
<b>Electrical modules</b>	PHOENIX INLINE	PHOENIX INLINE
<b>Digital modules</b>	2 or 4 inputs 2 or 4 outputs, others on request	2 or 4 inputs 2 or 4 outputs, others on request
<b>Analog modules</b>	2 or 4 inputs (0-10 V, 0-20 mA, 4-20 mA, RTD, TC) 2 outputs (0-10 V, 0-20 mA, 4-20 mA) others on request	2 or 4 inputs (0-10 V, 0-20 mA, 4-20 mA, RTD, TC) 2 outputs (0-10 V, 0-20 mA, 4-20 mA) others on request
<b>Operating voltage</b>	24 V/DC	24 V/DC
<b>Permissible voltage tolerance</b>	+20%/-15% (by use of Type 0460: ±10%)	+20%/-15% (by use of Type 0461: ±10%)
<b>Residual ripple</b>	1 Vss	1 Vss
<b>Rated power per valve</b>	1 W (0.5 W nominal power after 120 ms)	1 W (0.5 W nominal power after 120 ms)
<b>Rated current per valve</b>	43 mA (28 mA holding current after 120 ms)	86 mA (56 mA holding current after 120 ms)
<b>Temperatures</b>		
Operating	0 to +55°C (by use of Type 0460: 0 to +50°C)	0 to +55°C (by use of Type 0461: 0 to +50°C)
Storage	-20 to +60°C	-20 to +60°C
<b>Rating</b>	IP20 IP65 in closed field housing	IP20 IP65 in closed field housing
<b>Approvals for hazardous areas</b>	on request	on request

Application example

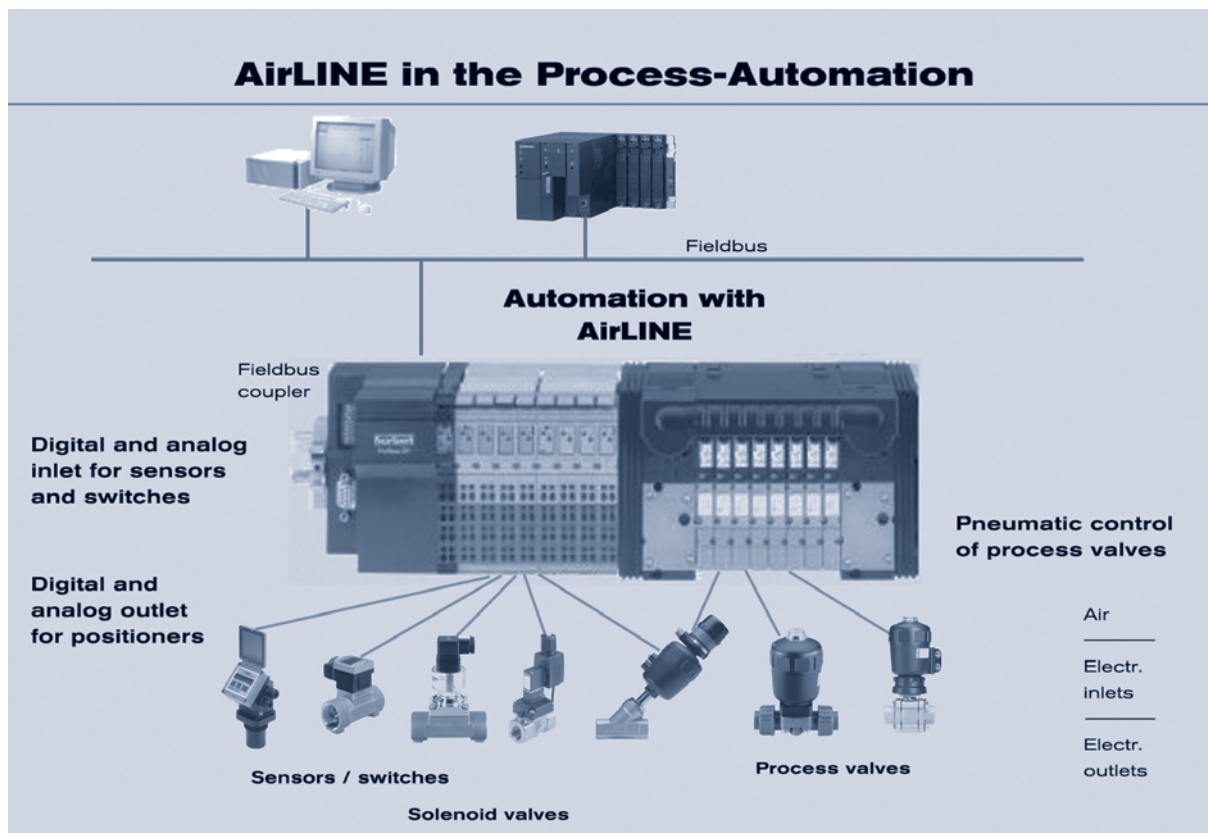

DTS 1000011131 EN Version: H Status: RL (released | freigegeben | validé) printed: 27.08.2008

## Configuration software

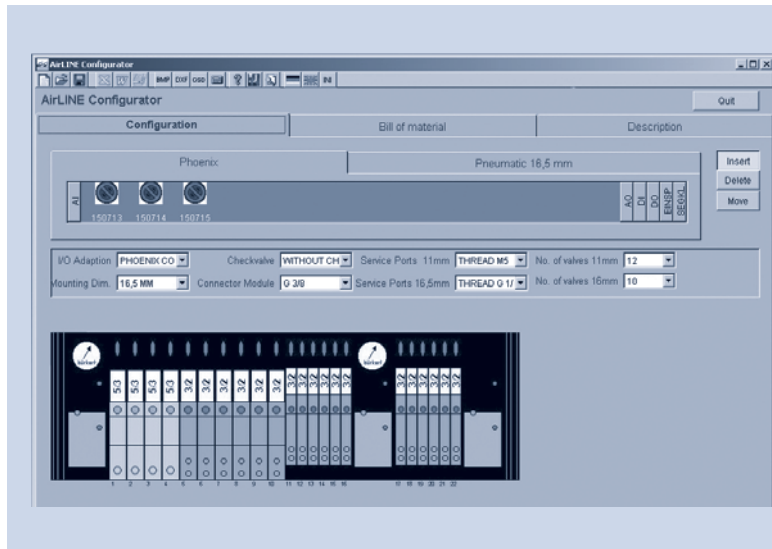

AirLine is a system of modular design which is precisely adapted to the specific requirements of the customer. Burkert offers a software program, the Configurator, for the simple, precise generation of the required configuration of each Airline system.

The Burkert Configurator defines:

- Number and types of valves
- Type of (intermediate) supplies

The results supplied by the Configurator:

- Bill of materials, incl. list prices
- Illustration

For more information consult individual datasheets, downloadable at [www.burkert.com](http://www.burkert.com)



Pneumatic modules and electrical interfaces for modules PHOENIX CONTACT INLINE

Pneumatic modules MP11

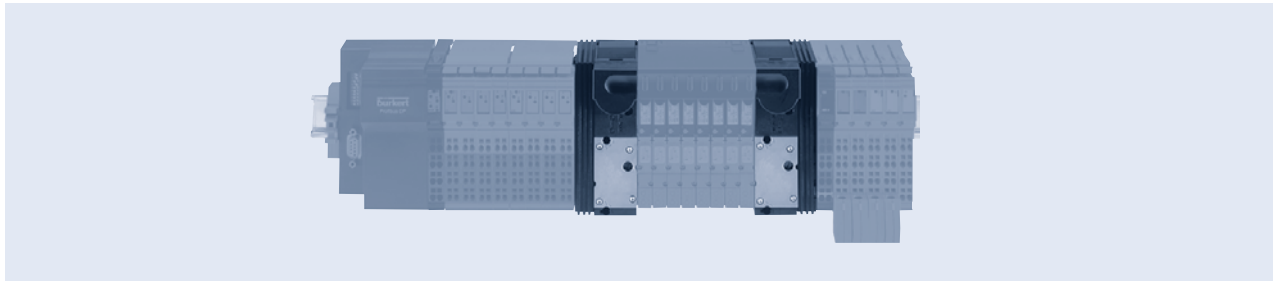

Connector module "left"

Description	Port connection	Item no.
Without pressure gauge	threaded port G 1/4	144 938
	threaded port NPT 1/4	150 236
	push-in 10 mm	150 237
With pressure gauge	threaded port G 1/4	150 235
	threaded port NPT 1/4	150 221
	push-in 10 mm	150 222

Technical data		Item no.
Measurements	bar, psi, KPa	167 071
Pressure range	-1 to 10 bar	
Media	clean + dry air, no aggressive gasses	
Port connection	G1/4	
Features	<ul style="list-style-type: none"> <li>▪ limit value monitoring</li> <li>▪ sensitivity setting</li> </ul>	

Connector module "right" and Pneumatic intermediate supply module

Description	Port connection	Item no.
Connector module "right"		
Without pressure gauge	threaded port G 1/4	144 939
	threaded port NPT 1/4	150 238
	push-in 10 mm	150 239
With pressure gauge	threaded port G 1/4	150 141
	threaded port NPT 1/4	150 142
	push-in 10 mm	150 143

Pneumatic intermediate supply module		
Without pressure gauge	threaded port G 1/4	150 622
	threaded port NPT 1/4	150 624
	push-in 10 mm	150 623
With pressure gauge	threaded port G 1/4	150 625
	threaded port NPT 1/4	150 627
	push-in 10 mm	150 626

Pneumatic module and electrical interfaces for modules PHOENIX CONTACT INLINE

AirLINE valve modules

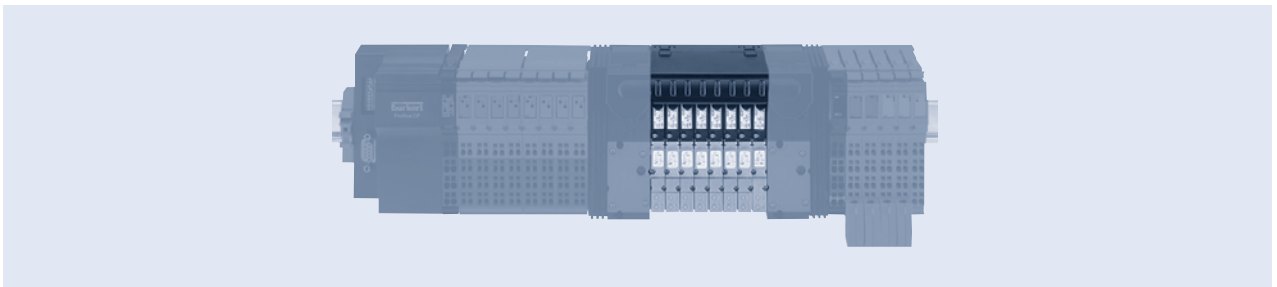

## Pneumatic basic module, electrical basic module and pilot valves

---

### 2 valves wide/2 valves wide with 2 x 3/2-way valve

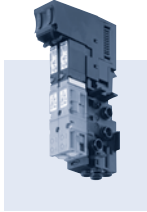

#### Service port 2 (A), 4 (B)

Threaded port M5  
 Threaded port M7  
 Push-in  $\varnothing$  6 mm  
 Push-in  $\varnothing$  1/4"  
 Push-in  $\varnothing$  5/32"

### 8 valves wide/8 valves wide with 2 x 3/2-way valve

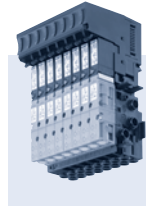

#### Service port 2 (A), 4 (B)

Threaded port M5  
 Threaded port M7  
 Push-in  $\varnothing$  6 mm  
 Push-in  $\varnothing$  1/4"  
 Push-in  $\varnothing$  5/32"

## Further pneumatic accessories

---

### Typ 0498

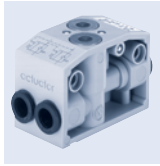

Double pilot controlled  
 check Valve

#### Available options on request

- Check valves in R, S and P-shut
- Covering plate for spare channels
- Channel separation plugs to build different pressure areas

11mm width per station: Multi-way solenoid valve Types 6524 and 6525

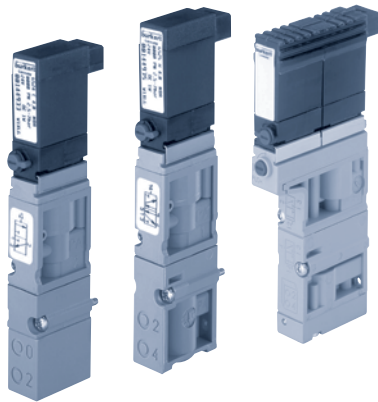

The solenoid valve Types 6524 and 6525 consist of a pneumatic valve body fitted with Type 6104 rocker pilot valve. The rocker principle allows switching of high pressure at low power consumption and fast response times. The pilot valves are equipped with manual override as a standard.

The 2 x 3/2-way valve version is the combination of two pilot rocker solenoid valves type 6104 and a pneumatic seat valve.

Specification	3/2-way valve	2 x 3/2-way valve
<b>Body material</b>	PA (polyamide)	
<b>Seal material</b>	FPM, NBR	
<b>Media</b>	Lubricated and non-lubricated dry air, neutral gases (5 µm-Filter)	
<b>Port connection</b>	Flange for MP11	
<b>Manual override</b>	As a standard feature	
<b>Voltage</b>	24 V DC	
<b>Nominal power</b>	1 W	2 x 1 W with reduction of power consumption
<b>Duty cycle</b>	Continuous operation (100% ED)	
<b>Elec. connection on valve</b>	Rectangular plug 2-pole with raster 5.08 mm	Rectangular plug 3-pole with raster 2.54 mm
<b>Mounting</b>	With 2 screws M2 x 20	With 2 screws M2 x 28
<b>Installation position</b>	As required, preferably with pilot valve upright	
<b>Flow rate: QNn value air [l/min]</b>	Measured at +20°C, 6 bar pressure at valve inlet and 1 bar pressure difference	
<b>Pressure ranges [bar]</b>	Measured as overpressure to the atmospheric pressure	
<b>Response times [ms]</b>	Measured according to ISO 12238	

Order chart for valves

Circuit function	Orifice [mm]	QNn value air [l/min]	Pressure range [bar]	Response times		Voltage/Frequency [V/Hz]	Item no.
				Opening [ms]	Closing [ms]		
<b>Circuit function C</b>  3/2-way valve, servo-assisted in de-energized position port 2 to atmosphere	4	300	Vac.-7	15	20	24 V DC	153 958
			1-7 <sup>1)</sup>	15	20	24 V DC	150 333
			2.5-7	12	20	24 V DC	144 933
			2.5-10	15	28	24 V DC	148 227
<b>Circuit function D</b>  3/2-way valve, servo-assisted in de-energized position port 2 pressurized	4	300	1.0-7 <sup>1)</sup>	12	20	24 V DC	150 334
			2.5-7	12	20	24 V DC	144 934
			2.5-10	15	28	24 V DC	152 139
<b>Circuit function H</b>  5/2-way valve, servo-assisted in de-energized position port 1 connected to port 2, port 4 exhausted	4	300	1.0-7 <sup>1)</sup>	15	20	24 V DC	150 335
			2.5-7	15	20	24 V DC	144 935
			2.5-10	20	28	24 V DC	150 610
<b>Circuit function C</b>  2 x 3/2-way valve, servo-assisted in de-energized position port 2/4 to atmosphere	4	300	1.0-7 <sup>1)</sup>	12	20	24 V DC	170 269 <sup>2)</sup>
			2.5-7	12	20	24 V DC	170 268 <sup>2)</sup>

<sup>1)</sup> Version with auxiliary air.

<sup>2)</sup> Version with integrated reduction of power consumption

11 mm width per station: Multi-way solenoid valve Types 0460



The solenoid valve Type 0460 consists of a pneumatic valve body fitted with a double coil pilot valve. The principle allows switching of high pressures together with low power consumption and fast response times. All valves are equipped with manual override as a standard.

Technical data	
<b>Body material</b>	Aluminium
<b>Seal material</b>	NBR
<b>Media</b>	Lubricated and non-lubricated dry air, neutral gases (5 µm-filter recommended)
<b>Port connection</b>	Flange
<b>Pneumatic module</b>	MP11
<b>Supply port 1 (P), 3 (R), 5 (S)</b>	G 1/4 NPT 1/4 Push-in connection Ø 10 mm
<b>Service port 2 (A), 4 (B)</b>	Push-in connection Ø 6 mm Push-in connection Ø 1/4" Push-in connection Ø 4 mm = ø 5/32" M5 M7
<b>Voltage</b>	24 V DC
<b>Electrical connection on valve</b>	Rectangular plug
<b>Manual override</b>	Standard
<b>Flow rate: Q<sub>Nn</sub>-value air l/min]</b>	Measured at +20°C, 6 bar pressure at valve inlet and 1 bar pressure difference
<b>Pressure ranges [bar]</b>	Measured as overpressure to the atmospheric pressure
<b>Response times [ms]</b>	Measured according to ISO 12238

Ordering chart valves

Circuit function	Orifice [mm]	Q <sub>Nn</sub> -value air [l/min]	Pressure range [bar]	Nominal power [W]	Response times		Item no.
					Opening [ms]	Closing [ms]	
<p>5/2-way valve, servo-assisted impulse version</p>	2.5	200	2.0-7.0	1	15	15	154 183
<p>5/3-way valve, servo-assisted in middle position all ports blocked</p>	2.5	200	2.0-7.0	1	15	20	154 184
<p>5/3-way valve, servo-assisted in middle position port 2 and 4 exhausted</p>	2.5	200	2.0-7.0	1	15	20	154 185

DTS 1000011131 EN Version: H Status: RL (released | freigegeben | validé) printed: 27.08.2008



Dimensions [mm]

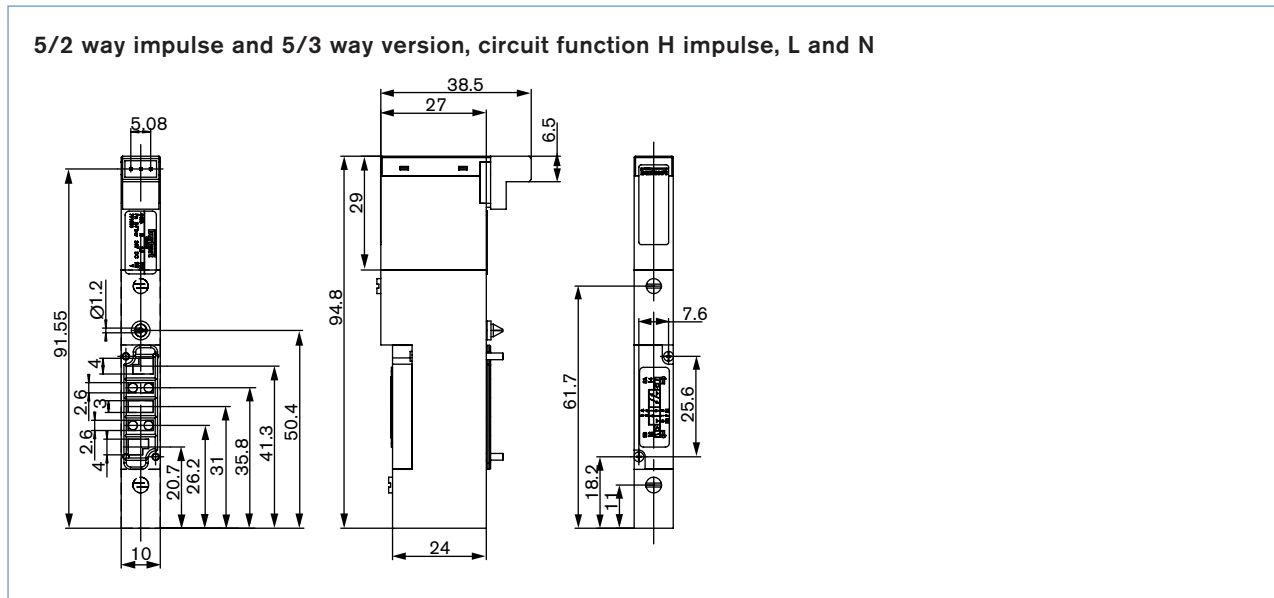

16.5mm width per station: Multi-way for solenoid valve Types 6526 and 6527



The solenoid valve Types 6526 and 6527 consist of a pneumatic valve body fitted with Type 6106 rocker pilot valve. The rocker principle allows switching of high pressure at low power consumption and fast response times. The pilot valves are equipped with manual override as a standard.

Specification	
<b>Body material</b>	PA (polyamide)
<b>Seal material</b>	NBR
<b>Media</b>	Lubricated and non-lubricated dry air, neutral gases (10 µm filter)
<b>Port connection</b>	Flange for MP12
<b>Manual override</b>	Standard
<b>Voltage</b>	24 V DC
<b>Nominal power</b>	2 W, 1W
<b>Duty cycle</b>	Continuous operation (100% ED)
<b>Elec. Connection on valve</b>	Tag connector acc. to DIN EN 175301-803 (previously DIN 43650) Form C
<b>Mounting</b>	With 2 screws M3x30
<b>Installation position</b>	As required, preferably with pilot valve upright

<b>Flow rate: QNn value air [l/min]</b>	Measured at +20°C, 6 bar pressure at valve inlet and 1 bar pressure difference
<b>Pressure ranges [bar]</b>	Measured as overpressure to the atmospheric pressure
<b>Response times [ms]</b>	Measured acc. to ISO 12238

Order chart for valves

Circuit functions	Orifice [mm]	QNn value air [l/min]	Pressure range [bar]	Nominal power [W]	Response times		Voltage/Frequency [V/Hz]	Item no.
					Opening [ms]	Closing [ms] <sup>3)</sup>		
<b>C</b> <p>3/2-way valve, servo-assisted in de-energized position port 2 to atmosphere</p>	6	700	1.0 - 10 <sup>1)</sup>	2	20	12	24 V DC	156 842
			1.0 - 10 <sup>1)</sup>	2	20	12	24 V DC	163 028 <sup>2)</sup>
			2.0 - 10	2	20	12	24 V DC	156 318
			2.0 - 10	2	20	12	24 V DC	158 944 <sup>2)</sup>
			2.0 - 8.0	1	20	17	24 V DC	156 840
<b>D</b> <p>3/2-way valve, servo-assisted in de-energized position port 2 pressurized</p>	6	700	1.0 - 10 <sup>1)</sup>	2	12	20	24 V DC	157 672
			1.0 - 10 <sup>1)</sup>	2	20	12	24 V DC	163 029 <sup>2)</sup>
			2.0 - 10	2	12	20	24 V DC	156 320
			2.0 - 10	2	20	12	24 V DC	158 946 <sup>2)</sup>
			2.0 - 8.0	1	17	20	24 V DC	156 841
<b>H</b> <p>5/2-way valve, servo-assisted in de-energized position port 1 connected to port 2, port 4 exhausted</p>	6	700	1.0 - 10 <sup>1)</sup>	2	20	12	24 V DC	156 828
			1.0 - 10 <sup>1)</sup>	2	20	12	24 V DC	163 030 <sup>2)</sup>
			2.0 - 10	2	20	12	24 V DC	156 337
			2.0 - 10	2	20	12	24 V DC	158 942 <sup>2)</sup>
			2.0 - 8.0	1	20	17	24 V DC	156 827
2.0 - 8.0	1	20	12	24 V DC	158 943 <sup>2)</sup>			

<sup>1)</sup> version with auxiliary air  
<sup>2)</sup> electric connection with manual override.  
<sup>3)</sup> closing time approx. 5 ms higher when used together with valve unit

16.5 mm width per station: Multi-way solenoid valve Type 0461

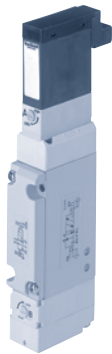

The solenoid valve Type 0461 consists of a pneumatic valve body fitted with a double coil pilot valve. The principle allows switching of high pressures together with low power consumption and fast response times. All valves are equipped with manual override as a standard.

Technical data	
Body material	Aluminium
Seal material	NBR
Media	Lubricated and non-lubricated dry air, neutral gases (10 µm-filter recommended)
Port connection	Flange
Pneumatic module	MP12
Supply port 1 (P), 3 (R), 5 (S)	G 3/8 NPT 3/8
Service port 2 (A), 4 (B)	G 1/8 NPT 1/8 Push-in connection Ø 8 mm
Operating voltage	24 V DC
Electrical connection on valve	Rectangular plug
Manual override	Standard
Flow rate: Q <sub>Nn</sub> -value air l/min]	Measured at +20°C, 6 bar pressure at valve inlet and 1 bar pressure difference
Pressure ranges [bar]	Measured as overpressure to the atmospheric pressure
Response times [ms]	Measured according to ISO 12238

Ordering chart valves

Circuit function	Orifice [mm]	Q <sub>Nn</sub> -value air [l/min]	Pressure range [bar]	Nominal power [W]	Response times		Item no.
					Opening [ms]	Closing [ms]	
<p>5/2-way valve, servo-assisted impulse version</p>	6	500	2.5-7.0	1	20	30	156 766
<p>5/3-way valve, servo-assisted in middle position all ports blocked</p>	6	500	2.5-7.0	1	15	50	156 767
<p>5/3-way valve, servo-assisted in middle position port 2 and 4 exhausted</p>	6	500	2.5-7.0	1	15	50	156 768

DTS 1000011131 EN Version: H Status: RL (released | freigegeben | valide) printed: 27.08.2008

Dimensions [mm]

5/2 way impulse and 5/3 way version, circuit function H impulse, L and N

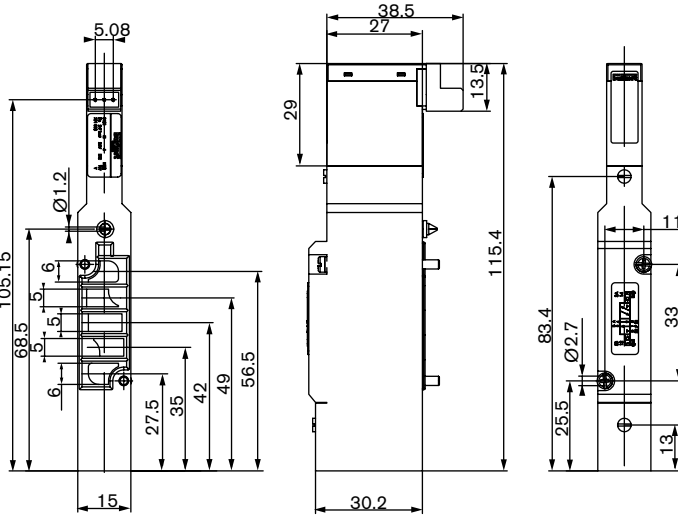

Electronic modules PHOENIX CONTACT INLINE

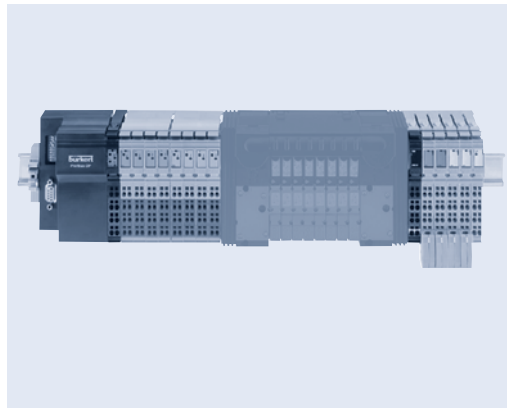

General specifications	
<b>Voltage supply</b>	24 V/DC (+20%/-15%)
<b>Electrical insulation</b>	
Logic - I/O	500 V/AC test voltage
I/O - functional ground	500 V/AC test voltage
<b>Wire connection</b>	Spring clamp terminals
<b>Local diagnostics on I/O segments</b>	
Bus active	LED green on
Comm power not present	LED green off
Comm power not present with bus inactive	LED green (flashes at 0.5 Hz)
I/O error	LED green (flashes at 2 Hz)
Previous device faulty	LED green (flashes at 4 Hz)
<b>Dimensions</b> (incl. connection terminal)	W x H x L
Profibus DP coupler	91 x 120 x 71.5 mm
InterBus-S coupler	48.8 x 120 x 71.5 mm
Segments (1 wide)	12.2 x 120 x 71.5 mm
(2 wide)	24.4 x 120 x 71.5 mm
(4 wide)	48.8 x 120 x 71.5 mm

Fieldbus modules (others on request)

Profibus DP/EN 51070; 12 MBaud; digital and analog signals



The Profibus DP fieldbus connects the AirLINE automation system to a Profibus DP network. The fieldbus coupler acts as a slave in the Profibus and a master in the lower level INLINE local bus.

The product is supplied with a disk containing the appropriate GSD (device master data) file for configuring the Profibus.

The INTERBUS diagnostics are supported by the Profibus DP fieldbus coupler, as are the typical diagnostics messages for the Profibus DP.

LED's facilitate accurate diagnostics at a local level.

<b>Interface</b>	Copper cable (RS-485), connected via SUB-B shield connector; supply electrically isolated, shielding directly connected with functional grounding
<b>Current consumption (24 V DC supply)</b>	
Without connected E/A terminals	< 100 mA
With max. no. of connected E/A terminals	1.25 A
<b>Max. total perm. curr. consumption of all E/A terminals</b>	
Logic power (7.5 V DC)	≤2 A
Analog supply (24 V DC)	≤0.5 A
<b>Local diagnostics</b>	
24 V main circuit supply present (UM)	LED green
24 V segment circuit supply present (US)	LED green
No communication on Profibus (BF)	LED red
Error-indication number and type (FS / FN)	LED red (2x)
<b>Profibus data</b>	
Number of devices per station	Max. 63
Sum of all I/O data per station	Max. 192 bytes
Max. fieldbus coupler current (for supplying the I/O module logic)	2 A at U L
Max. additional current (for supplying the analog terminals)	0.5 A at U ANA
<b>24 V main supply U M</b>	
Connection method	Spring clamp terminals
Recommended cable lengths	Max. 30 m (do not route cable through outdoor areas)
<b>Safety devices</b>	
Overvoltage	Yes
Polarity reversal	Yes
Provide an external fuse for the 24 V area	

**Electronic modules PHOENIX CONTACT INLINE**

**DeviceNET; 125, 250 and 500 kBaud; digital and analog signals**

<b>Diagnostic LED indicators</b>	
Network status	Indicates DeviceNET TM communication
Module status	Indicates module or inline station
Logic supply status	Indicates proper power to the local bus
Segment power (US)	Indicates proper 24 V/DC segment I/O power
Main power (UM)	Indicates proper 24 V/DC main power
<b>Supported DeviceNETTM features</b>	
I/O peer to peer	Yes
Explicit peer to peer messaging	Yes
Configuration consistency	Yes
Faulted node recovery	Yes
Baud rates 125K	Yes
250K	Yes
500K	Yes
I/O slave messaging	
Polled	Yes
Cyclic	Yes
Change of state	Yes
Bit strobe	Yes
<b>24 V main supply U M</b>	
Connection method	Spring clamp terminals
Recommended cable lengths	Max. 30 m (do not route cable through outdoor areas)
<b>Safety devices</b>	
Surge voltage	Yes
Polarity reversal	Yes
Provide an external fuse for the 24 V area	

The DeviceNETTM fieldbus coupler allows the AirLINE system to communicate on a DeviceNETTM network as a group 2 slave.

The coupler is housed in a 4-module width package that contains the front panel wiring and diagnostic indicators for both the local bus and DeviceNETTM communications.

DTS 1000011131 EN Version: H Status: RL (released | freigegeben | valide) printed: 27.08.2008



## Electronic modules PHOENIX CONTACT INLINE

### Fieldbus modules (others on request)

#### InterBus-S: 500 kBaud; digital and analog signals

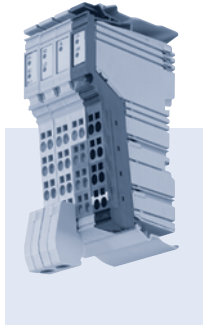

The INTERBUS terminal connects the AirLINE system with the INTERBUS network.

The bus terminal has the following functions within an AirLINE system:

- Refreshing the remote bus signals
- Decoupling the outgoing remote bus of the connected I/O modules using a software command
- Supplying the connected I/O modules using an integrated power supply unit
- Connection to functional earth when installed on the mounting rail

<b>Interfaces</b> INTERBUS remote bus (I/O) Supply voltage INTERBUS local bus	2 x 6 pos. INLINE shield connector 8 pos. INLINE input connector INLINE potential distribution
<b>Current consumption</b> Without connected IB IL - I/O terminals	Approx. 100 mA
<b>Max. total perm. curr. consumption of all I/O terminals</b> Logic power (7.5 V DC) Analog supply (24 V DC)	≤2 A ≤0.5 A
<b>Local diagnostics</b> Remote bus active (BA) Remote bus connection OK (RC) Outgoing remote bus disabled (RD) Local bus branch disabled (LD) Local bus error (E) Communication power (UL) Supply voltage segment circuit (SG) Operating voltage (US)	LED green LED green LED red LED red LED red LED green LED green LED green
<b>INTERBUS data</b> Max. distance from next remote bus station Number of connectable INLINE terminals (without any additional input terminals)	400 m 63 (note permissible current consumption)
<b>Programmable functions</b> Local bus branch disabled Local bus reset Local bus disabled Remote bus disabled Remote bus reset	Yes Yes Yes Yes Yes
<b>Local functions</b> Reconfiguration input	A push button can be connected via an 8 pos. INLINE connector
<b>General data</b> Polarity reversal protection	Yes
<b>Connector set for bus terminal</b>	1

### AS-Interface Gateway



This AS-Interface gateway allows to operate an ASi 2.1 system as a subsystem AirLINE. The configuration of ASi is done on site by means of pushbuttons directly on the gateway, or by means of parameterisation via software. The gateway has a 2-digit, 7-segment display to indicate status and diagnostics information.

As ASi master, the gateway can operate up to 62 ASi slaves according to the new specification 2.1.

## Accessory modules (others on request)

### Power terminal block – fused

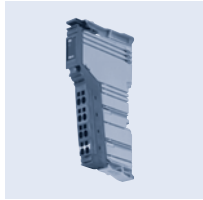

<b>Max. nominal current</b>	10 A
<b>Local diagnostics</b> Operating voltage display (US)	LED green
<b>General data</b> Polarity reversal protection Surge voltage protection Overload protection	Yes Yes No
<b>Fuse (fused version)</b>	6.3 A

Power and segment terminals provide the power supply for an Interbus station. The power terminal is used to supply the I/O circuit. The supply enables the electrical isolation of the previous isolated group.

Power terminals are available with or without integrated fuses.

### Segment terminal block – fused/not fused

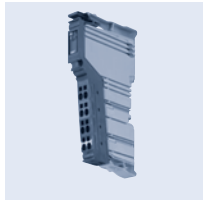

<b>Interfaces</b> Supply voltage INTERBUS local bus	Via voltage jumper Voltage jumper
<b>Max. nominal current</b>	10A
<b>Local diagnostics</b> Operating voltage display	Yes
<b>General data</b> Polarity reversal protection Surge voltage protection Overload protection	No No No

Power and segment terminals provide the power supply for an Interbus station. The power terminal is used to supply the I/O circuit.

The segment terminal can be used to group any adjacent terminals within a station into separate segments.

Segment terminals are available with or without integrated fuses.

## Remote I/O modules (others on request)

### Digital input module DI – 2 and 8 channel

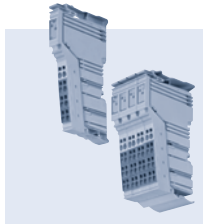

<b>Supply</b> Current consumption  I/O voltage Residual ripple Voltage tolerance Drawing initiator supply	Approx. 30 mA (2 channel) Approx. 50 mA (8 channel) 24 V/DC (via voltage jumper) 5% 19.2 V up to 30 V/DC (ripple included) Segment circuit
<b>Inputs</b> Number of inputs Connection method Input current per channel Permissible range Nominal current  Delay time at signal change	2 or 8 4 wire 5 mA at 24 V/DC -30 V < U in < +30 V /DC "1" signal +15 V ≤ U in ≤ +30 V/DC "0" signal -30 V ≤ U in ≤ +5 V/DC In μs range

Digital INTERBUS INLINE input terminals are designed for the connection of digital signals such as those generated by limit switches, push buttons or proximity switches.

## Remote I/O modules (others on request)

## Digital output module DO – 2 and 8 channel



<b>Supply</b>	
Logic supply (via voltage jumper)	7.5 V DC
Current consumption	33 mA (2 channel) 60 mA (8 channel)
Periphery voltage	24 V DC
Ripple	5%
Voltage range	19.2 to 30 V DC
Output voltage extraction	Segment circuit
<b>Diagnostic messages via the bus</b>	
Short circuit, overload of an output	Yes
<b>Inputs</b>	
Number of outputs	2 or 8
Connection method	4 wire
Output voltage	Us - 1 V
Signal delay	In $\mu$ s range
Output current	500 mA (2- and 8 channel)
	Max. / output
	4 A (8 channel)
	Max. / terminal
	1 A (2 channel)
	12 W (2- and 8 channel)
Nominal load	Ohmic
Nominal load	Lamp
Overload protection	Yes
Short circuit protection of outputs	Yes

Digital INTERBUS INLINE output terminals are designed for the connection of digital actuators such as solenoid valves, contactors or optical indicating facility.

## Analog input module AI – 2 channel; voltage and current signals

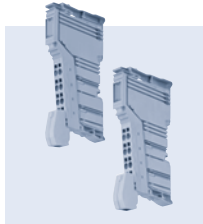

<b>Supply</b>	
Logic supply (via voltage jumper)	7.5 V DC
Current consumption	45 mA
Analog voltage (via voltage jumper)	24 V DC
Current consumption	12 mA
<b>Diagnostics messages via the bus</b>	
Ovrange	Yes
Error of internal I/O voltage	Yes
<b>Line interrupt detection</b>	
	Yes, for the range of 4–20 mA
<b>Inputs</b>	
Number of inputs	2, single ended
Connection method	2-wire (shielded)
Input range	0–10 V, $\pm$ 10 V; 0–20mA, 4–20mA, 20mA
Input resistance	220 $\Omega$ (V signals); 50 $\Omega$ (mA signals);
Measurement principle	Successive approximation
Representation of measured value	16 bits two's complement
Measured value resolution	16 bits (15 bits + sign)
A/D conversion time per channel	120 $\mu$ s
Process data update	< 1.5 ms
3 dB cut-off frequency	15 Hz/ 40 Hz without averaging
Basic error limit	0.015 %

Analog INTERBUS input terminals are used for the connection of standard sensors for detecting current or voltage signals.

Terminal features include:

- High accuracy
- Fast measurement
- Very high noise and common mode suppression
- 16 bit resolution

RTD and TC inputs on request.

## Remote I/O modules (others on request)

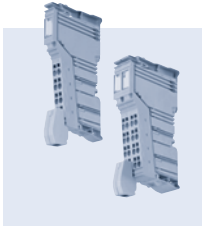

<b>Supply</b>	
Logic supply	7.5 V DC
Current consumption	40 mA
Analog voltage	24 V DC
Current consumption	65 mA
<b>Outputs</b>	
Number of outputs	1
Connection method	2 wire
Output range	0–10 V, 0–20mA, 4–20mA
Load impedance	>2 k $\Omega$
Representation of output values	16 bit
DAC resolution	16 bit
A/D conversion time per channel	<100 $\mu$ s
Basic error limit	0.05 %
Error type	U OUT $\pm$ 0.5% I OUT $\pm$ 0.8%
Transient protection of outputs	Yes

Analog output modules are used in applications which require the control of analog actuators.

Normal current and voltage output ranges can be configured individually for these terminals.

All analog signals are provided with a resolution of 16 bit.

### Ordering chart fieldbus modules

Item	Description	Item no.
PROFIBUS DP	EN 51070; 12 MBaud; digital and analog signals	148 837
Interbus-S	EN 50254; digital and analog signals	150 697
DeviceNET	125-500 kBaud; digital and analog signals	on request
ASI Gateway	ASI master for up to 62 ASi slaves	on request

### Ordering chart remote I/O modules

Item	Description	Item no.
DI 2 channel	24V/DC input	150 709
DI 8 channel	24 V/DC input	150 711
DO 2 channel	2.0 A	150 703
DO 8 channel	0.5 A	150 705
AI 2 channel	Thermocouple	150 714
AI 2 channel	RTD	150 715
AI 2 channel	0-20 mA, 4-20 mA, 0-1.0 V	150 713
AO 1 channel	0-10 V	150 708
AO 1 channel	0 – 20 mA, 4-20 mA, 0-10 V	150 707

### Ordering chart accessory modules

Item	Description	Item no.
Power terminal block	Fused	150 699
Segment terminal block	Fused	150 701
Segment terminal block	Not fused	150 700

Pneumatic modules and electrical interfaces for modules PHOENIX INLINE

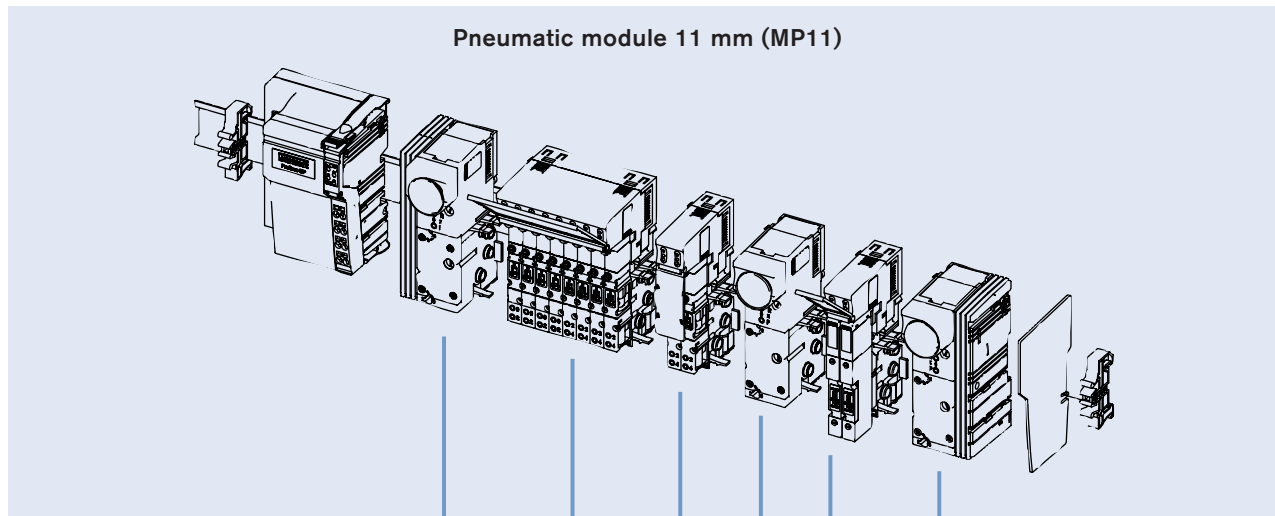

Pneumatic module 11 mm (MP11)

**Connector module "left", with or without pressure gauge / digital pressure module**  
 Threaded port G 1/4  
 Threaded port NPT 1/4  
 Push-in 10 mm

**Connector module "right", With or without pressure gauge**  
 Threaded port G 1/4  
 Threaded port NPT 1/4  
 Push-in 10 mm

**Pneumatic basic module, electrical basic module and pilot valves**  
 4 valves wide (pneumatic 2 x 2valves wide) (4 x 11 mm)

**Pneumatic basic module, electrical basic module and pilot valves**  
 2 valves wide (2 x 11 mm)  
**Service port 2 (A), 4 (B)**  
 Threaded port M5  
 Threaded port M7  
 Push-in ø 4 mm and 5/32"  
 Push-in ø 6 mm  
 Push-in ø 1/4"

**Service port 2 (A), 4 (B)**  
 Threaded port M5  
 Threaded port M7  
 Push-in ø 4 mm and 5/32"  
 Push-in ø 6 mm  
 Push-in ø 1/4"

**2 valves wide (2 x 11 mm)**  
**Service port 2 (A), 4 (B)**  
 Threaded port M5  
 Threaded port M7  
 Push-in ø 4 mm and 5/32"  
 Push-in ø 6 mm  
 Push-in ø 1/4"

**Intermediate supply module, with or without pressure gauge**  
 Threaded port G 1/4  
 Threaded port NPT 1/4  
 Push-in 10 mm

DTS 1000011131 EN Version: H Status: RL (released | freigegeben | validé) printed: 27.08.2008



Pneumatic modules and electrical interfaces for modules PHOENIX INLINE

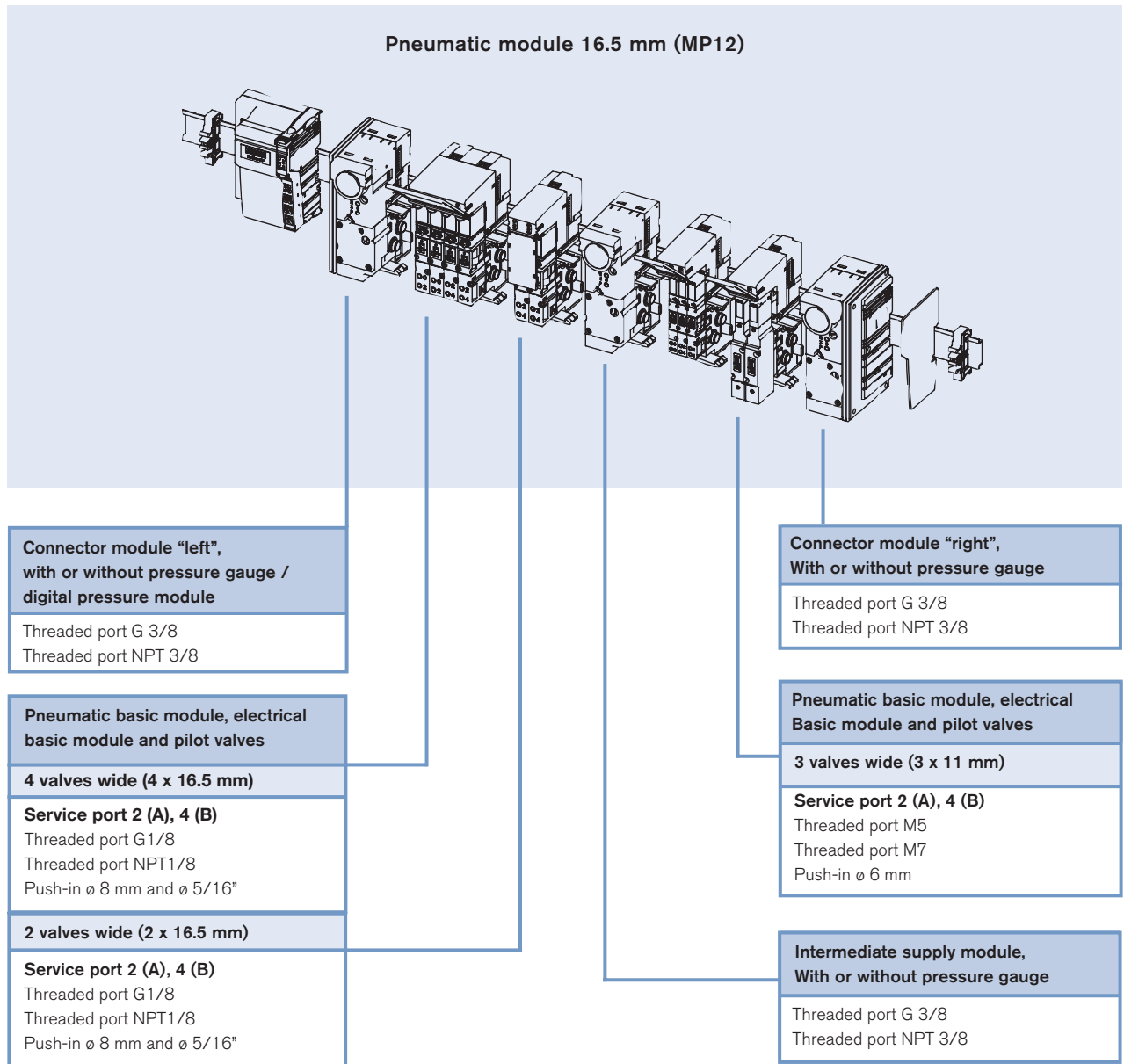

DTS 1000011131 EN Version: H Status: RL (released | freigegeben | validé) printed: 27.08.2008

Dimensions [mm]

11 mm mounting dimensions for Type 6524 / 6525

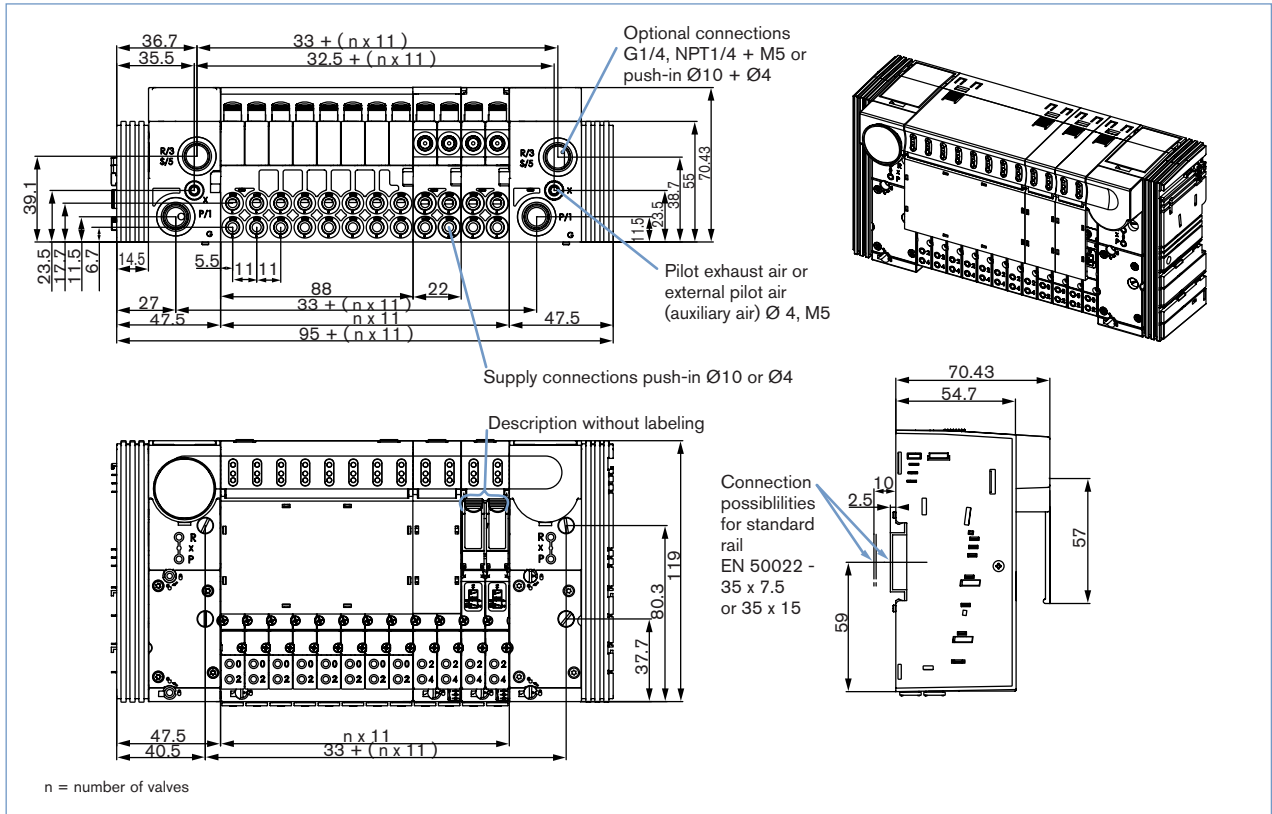

11 mm mounting dimensions for Type 6524 2 x 3/2-way valve

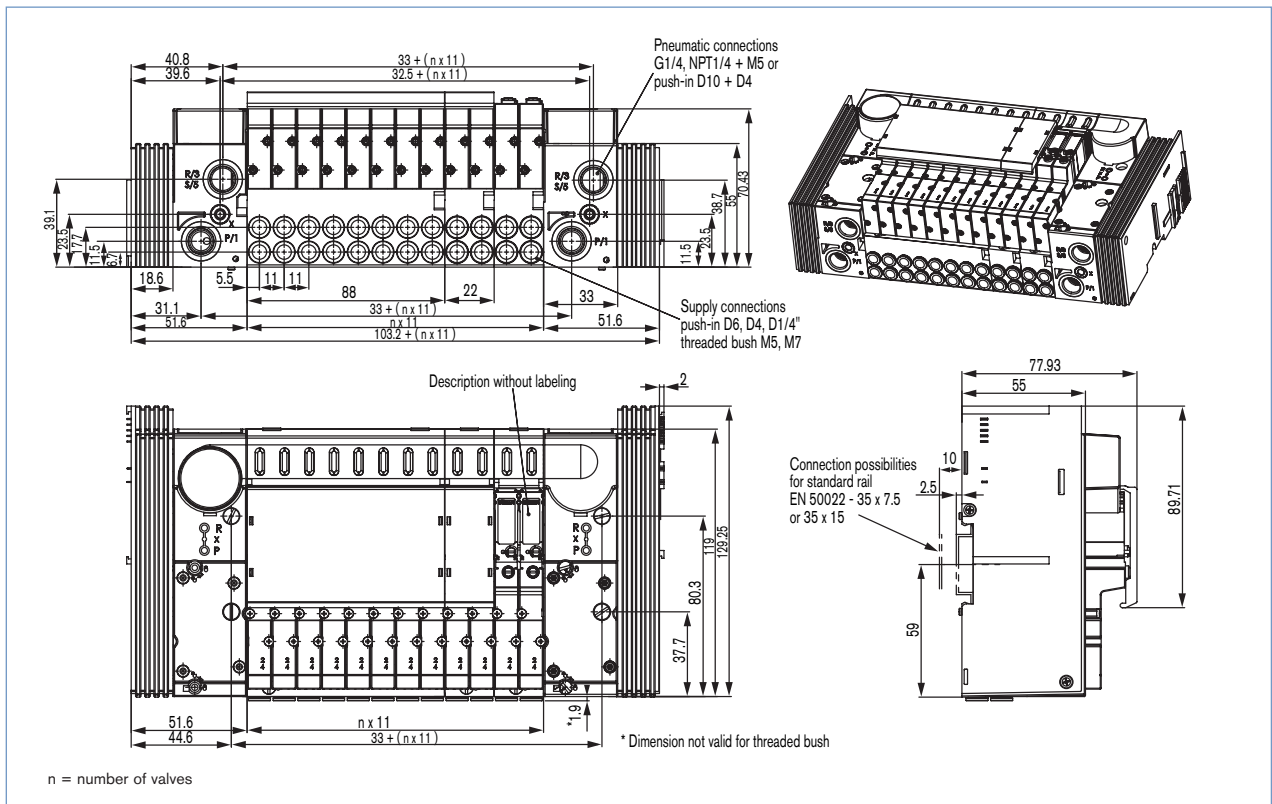

DTS 1000011131 EN Version: H Status: RL (released | freigegeben | valide) printed: 27.08.2008

Dimensions [mm]

16.5 mm mounting dimensions for Type 6526 / 6527

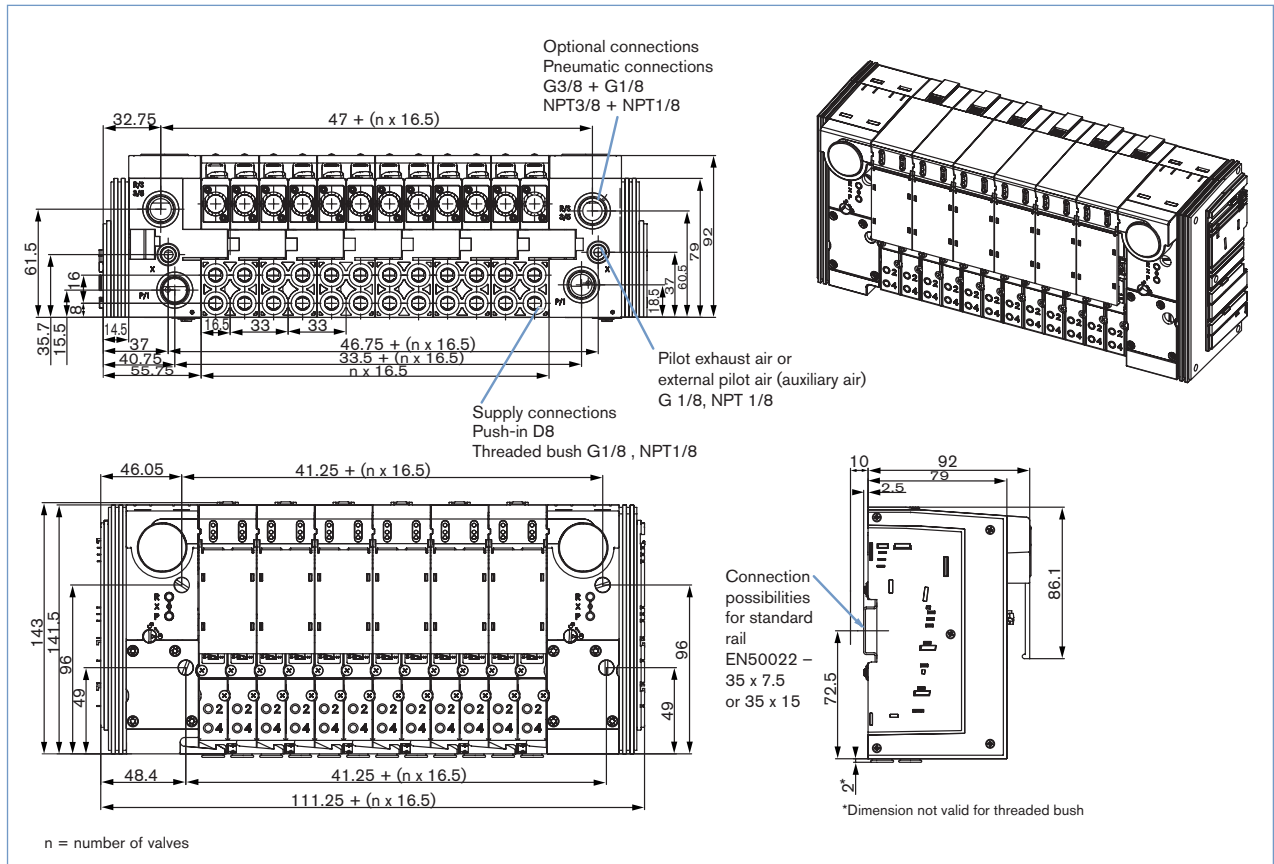

DTS 1000011131 EN Version: H Status: RL (released | freigegeben | valide) printed: 27.08.2008

To find your nearest Bürkert facility, click on the orange box →

[www.burkert.com](http://www.burkert.com)

In case of special application conditions,  
please consult for advice.

We reserve the right to make technical  
changes without notice.

0711/5\_EU-en\_00891828