

# rotork®

Keeping the World Flowing  
for Future Generations



## Noah SA Range

Compact part-turn electric actuators



Highly compact part-turn electric actuators designed to provide reliable valve control in limited space industrial applications.



Rotork is a market-leading global provider of mission-critical flow control and instrumentation solutions for the industrial actuation and flow control markets. These include oil and gas, water and wastewater, power, chemical, process and industrial applications.

Customers rely on us for innovative, high quality and dependable solutions for managing the flow of liquids, gases and powders. We help customers around the world to improve efficiency, reduce emissions, minimise their environmental impact and assure safety.

Our reliability record is second to none. Our products are designed with safety and performance at their core and are put through vigorous testing and certified to international standards. Our products are certified for use in the world’s most dangerous and hazardous areas.

**Partnering with us provides the following:**

- Assured safety and reliability
- Industry leading accuracy and efficiency
- Proven technology that works with all network control systems
- Product range with solutions to suit every application
- Assistance with plant planning, development and maintenance through our local support services
- We have innovative research and development centers throughout the world



**Contents**

Rotork Group	03	Noah SA05X, SA09X	09
Contents	03	Standard specifications	09
Inside the Noah SA Actuator	04	Performance data	09
Noah SA003	06	Optional extras	09
Standard specifications	06	Noah SA PCU	10
Performance data	06	Standard specifications	10
Optional extras	06	Performance data	10
Noah SA005, SA009	07	Optional extras	10
Standard specifications	07	Standard wiring diagram	11
Performance data	07	Noah SA SCP	12
Optional extras	07	Standard specifications	12
Noah SA005L, SA009L	08	Performance data	12
Standard specifications	08	Optional extras	12
Performance data	08	Internal capacitor specifications	13
Optional extras	08	Standard wiring diagram	13
		<b>Dimensional Data</b>	<b>14</b>

© Rotork 2025 all rights reserved. The name Rotork is a registered trademark. Rotork recognises all registered trademarks. The Bluetooth® word mark and logos are registered trademarks owned by Bluetooth SIG, Inc. and any use of such marks by Rotork is under license. Published and produced in the UK. POLTG1025. Rotork reserves the right to amend and change specifications without prior notice. For the latest version visit rotork.com

## Noah SA

Highly compact part-turn electric actuators waterproof to IP67.

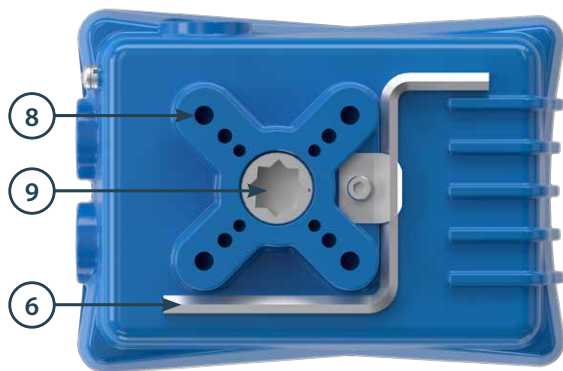
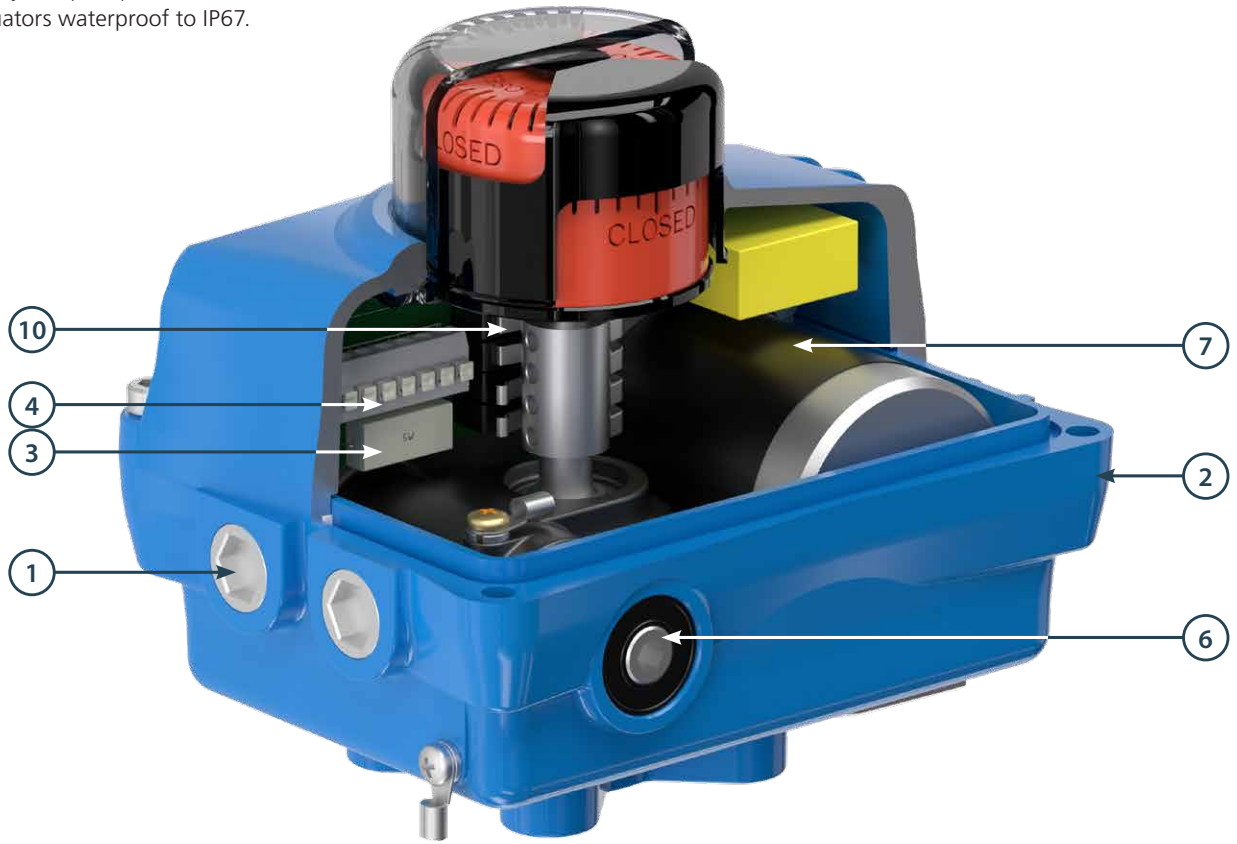

## 1. Cable entry

Standard Specification: 2-PF ½"

Optional: M20 x Pitch 1.5, NPT ½"

## 2. Outer case

The aluminum alloy casting is oxide film treated then powder coated (Polyester, TGIC-Free) to provide the best corrosion protection performance in any environment.

Optional - Explosionproof: Exd IIB T4 (except SA003 model)

## 3. Internal heater

The built-in internal heater prevents condensation and moisture forming inside the actuator to protect the internal components.

## 4. Terminal block

The terminal block is WAGO-structured allowing for simple wiring and is highly resistant to vibration and corrosion.



## 5. Position indicator

An LED lamp within the indicator illuminates the cover when Full Open and Full Close operations are completed. The standard SA features a domed position indicator cover while the explosionproof version uses a highly robust flat design suitable for explosionproof certification.



## 6. Manual operation

The SA range allows manual drive operation by inserting the included handle (attached on the base of the actuator) into the side of the actuator as shown below and rotating clockwise or anti-clockwise to manually operate the actuator.



## 7. Motor

Supply voltages for customer selection include 1-phase (110/220 VAC) and 24 VDC. Noah SA range actuators include a built-in thermal protector to protect the motor in case of motor overload.

## 8. Base

Mounting dimensions to ISO5211 standard, facilitating direct assembly to valves and dampers

Standard specifications - F03, F05, F07

## 9. Output shaft / valve stem connection

The SA range includes a standard valve stem connection with 14x14, with optional 11x11 and 9x9 inserts available.

Note: SA003 : 11x11, 9x9 only

## 10. Limit switch

A built-in mechanical cam-type limit switch is included which accurately controls the position of valves and rotating devices. The simple design and structure allows for easy adjustment.

Standard specifications



Waterproof rating	Waterproof ingress protection IP67
Operating temperature range	Tamb -20 to 70 °C (-4 to +158 °F)
Power supply	110 / 220 VAC 50/60 Hz / AC/DC 24 V
Indicator	Dome type (built-in LED)
Limit switch	2ea Open/Close + 2ea Open/Close (250 VAC) Non-voltage contacts
Travel angle	0~90°
Manual override	Using a hex wrench (6 mm hex)
Cable entries	2-PF ½" (Options: 2-M20 x Pitch 1.5, 2-NPT ½")
Heater	2x3 W
Case material	Aluminium
Lubricant	Shell Gadus S2 V220 2
Surface treatment	Anodising
Standard paint finish	Polyester powder coating (TGIC-free)

Performance data

Model	Options	Torque		Operating time (90°/sec)		Motor rating (W)	Rated current (A) 60 Hz				Duty cycle	Number of handle turns	Weight		Valve application range (10K)
							1-phase (AC)			DC			kg	lbs	
		Nm	lbf.ft	50 Hz	60 Hz	DC motor	24 V	110 V	220 V	24 V	S2 (min)				
SA003	ON-OFF	30	22	17	15	25	1	0.4	0.16	1.4	15	7.5	1.7	3.7	2way Screw Ball Valve : ~25A 3way Screw Ball Valve: ~20A
		20	15	9	-	25	1	0.4	0.16	1.4	15	7.5	1.7	3.7	2way Screw Ball Valve : ~20A 3way Screw Ball Valve: ~15A

Optional extras

AC24V	Control board for 24 VAC power supply
-------	---------------------------------------

Standard specifications



Waterproof rating	Waterproof ingress protection IP67
Operating temperature range	Tamb -20 to 70 °C (-4 to +158 °F)
Power supply	110 / 220 VAC 50/60 Hz / AC/DC 24 V
Indicator	Dome type (built-in LED)
Limit switch	2ea Open/Close+ 2ea Open/Close (250 VAC)
Travel angle	90° ±5° (up to 270° when extended)
Self-locking	Prevention of reverse rotation by two-stage worm gear
Manual override	Using an L-shaped wrench (6 mm hex)
Cable entries	2-PF ½" (Options: 2-M20 x Pitch 1.5, 2-NPT ½")
Heater	5 W
Case material	Aluminium
Lubricant	Shell Gadus S2 V220 2
Surface treatment	Anodising
Standard paint finish	Polyester powder coating (TGIC-free)

Performance data

Model	Options	Torque		Operating time (90°/sec)		Motor rating (W)	Rated current (A) 60Hz				Duty cycle	Number of handle turns	Weight		Valve application range (10K)
							1-phase (AC)			DC			kg	lbs	
		Nm	lbf.ft	50 Hz	60 Hz	DC motor	24 V	110 V	220 V	24 V	S2 (min)				
SA005	ON-OFF	50	37	17	14	6	1.8	0.35	0.23	1.8	15	6	2.8	6.2	BFV: ~65A Ball Valve : ~32A
SA009	ON-OFF	90	66	32	26	6	2.1	0.35	0.25	2.1	15	4.5	2.8	6.2	BFV: ~100A Ball Valve : ~50A

Optional extras

AC24V	Control board for 24 VAC power supply
-------	---------------------------------------

**Standard specifications**



<b>Waterproof rating</b>	Waterproof ingress protection IP67
<b>Operating temperature range</b>	Tamb -20 to +70 °C (-4 to +158 °F)
<b>Power supply</b>	110 / 220 VAC 50/60 Hz / AC/DC 24 V
<b>Indicator</b>	Dome type (built-in LED)
<b>Limit switch</b>	2ea Open/Close + 2ea Open/Close (250 VAC) non-voltage contacts
<b>Travel angle</b>	90° ±5° (up to 270° when extended)
<b>Self-locking</b>	Prevention of reverse rotation by two-stage worm gear
<b>Manual override</b>	Using an L-shaped wrench (6 mm hex)
<b>Cable entries</b>	2-PF ½" (Options: 2-M20 x Pitch 1.5, 2-NPT ½")
<b>Heater</b>	5 W
<b>Case material</b>	Aluminium
<b>Lubricant</b>	Shell Gadus S2 V220 2
<b>Standard paint finish</b>	Anodising

**Performance data**

Model	Options	Torque		Operating time (90°/sec)		Motor rating (W)	Rated current (A) 60Hz				Duty cycle	Number of handle turns	Weight		Valve application range (10K)
							1-phase (AC)			DC			kg	lbs	
		Nm	lbf.ft	50 Hz	60 Hz	DC motor	24 V	110 V	220 V	24 V	S2 (min)				
SA005L	PCU	50	37	17	14	25	1.8	0.35	0.23	1.8	15	6	3.2	7.1	BFV: ~65A BV: ~32A
	SCP	50	37	8	8	25	-	0.8	0.51	2.25		6	4.3	9.5	
SA009L	PCU	90	66	32	26	25	2.1	0.35	0.25	2.1	15	4.5	3.2	7.1	BFV: ~100A BV: ~50A
	SCP	90	66	13	15	25	-	0.8	0.51	2.25		4.5	4.3	9.5	

**Optional extras**

<b>AC24V</b>	Control board for 24 VAC power supply
<b>Potentiometer Unit (PIU)</b>	Outputs actuator position as a 0-1 kΩ signal
<b>Proportional Control Unit (PCU)</b>	Used to control the actuator so that the opening/closing degree of the valve is proportional to the input signal.
<b>Current Position Transmitter (CPT)</b>	Used when changing the resistance value of a potentiometer directly connected to the actuator to a current value and using the position of the actuator as the current value.
<b>Super Capacitor (SCP)</b>	A super capacitor device is built into the actuator so that when power is cut off, it operates in the open/closed/stop position set by the user.

Standard specifications



Waterproof, explosion-proof rating	Waterproof ingress protection IP67 Explosionproof Ex d IIB T6
Operating temperature range	Tamb -20 to +55 °C (-4 to +131 °F)
Power supply	110 / 220 VAC 50/60 Hz / AC/DC 24 V
Indicator	Flat type
Limit switch	2ea Open/Close + 2ea Open/Close (250 VAC) non-voltage contacts
Travel angle	90° ±5° (up to 270° when extended)
Self-locking	Prevention of reverse rotation by two-stage worm gear
Manual override	Using an L-shaped wrench (6 mm hex)
Cable entries	2-PF ½" (Options: 2-M20 x Pitch 1.5, 2-NPT ½")
Heater	5 W
Case material	Aluminium
Lubricant	Shell Gadus S2 V220 2
Surface treatment	Anodising
Standard paint finish	Polyester powder coating (TGIC-free)

Performance data

Model	Options	Torque		Operating time (90°/sec)		Motor rating (W)	Rated current (A) 60Hz				Duty cycle	Number of handle turns	Weight		Valve application range (10K)
							1-phase (AC)			DC					
		Nm	lbf.ft	50 Hz	60 Hz	DC motor	24 V	110 V	220 V	24 V	S2 (min)	kg	lbs		
SA05X	EXP	50	37	17	14	6	1.8	0.35	0.23	1.8	15	6	5	11.0	BFV: ~65A
															BV: ~32A
SA09X	EXP	90	66	32	26	6	2.1	0.35	0.25	2.1	15	4.5	5	11.0	BFV: ~100A
															BV: ~50A

Optional extras

AC24V	Control board for 24 VAC power supply
Potentiometer Unit (PIU)	Outputs actuator position as a 0-1 kΩ signal
Proportional Control Unit (PCU)	Used to control the actuator so that the opening/closing degree of the valve is proportional to the input signal.
Current Position Transmitter (CPT)	Used when changing the resistance value of a potentiometer directly connected to the drive shaft into a current value and using the position of the actuator as the current value.
Super Capacitor (SCP)	A super capacitor device is built into the actuator so that when power is cut off, it operates in the open/closed/stop position set by the user.

## Standard specifications

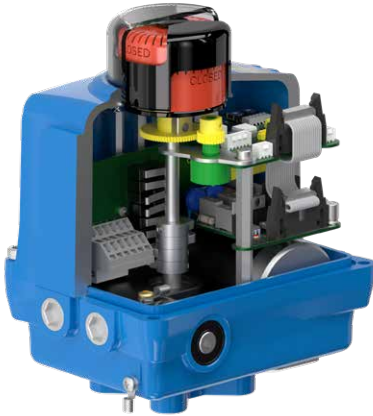

Input power	90~230 VAC $\leq$ 10%, 50/60 Hz 24 VDC/ 24 VAC Input power must match motor ratings
Command signal	4-20 mA DC (Default), 0-5 VDC, 0-10 VDC, 1-5 VDC, 2-10 VDC
Deadband	1~7.5% (1 scale 0.5%)
Output signal	4-20 mA DC
Load resistance	7,500 $\Omega$
Terminal block	YW 396 2P(3EA), 3P, 5P terminal block
Status display method	Power (blue), Fault (yellow), Open (red). Close (Green) LED lamp
Manual override	Using an L-shaped wrench (6 mm hex)
Output terminal	2-PF 1/2" (Options: 2-M20 x Pitch 1.5, 2-NPT 1/2")
Heater	5 W
Parameters	Deadband: 0.2 mA Modulating starting time: 1 sec
Resolution	At least 1/1000"
Operating temperature range	Tamb -14 to +60 °C (+6.8 to +140 °F)
Maximum ambient humidity	90% RH max. (non-condensing)
Insulation strength	1,500 VAC 1 min.
Insulation resistance	500 VDC 30M2 min.

## Proportional Control Unit (PCU) Actuator

The PCU is used to control the opening of a valve according to the user's input signal. It can be used to control pressure, flow rate, temperature, and water level in pipes.

Noah SA PCU actuators can use a variety of input power supplies which can be selected from: 4-20 mA, 0-5 VDC, 0-10 VDC, 1-5 VDC, 2-10 VDC. Output value is 4-20 mA.

## Performance data

Model	Options	Torque		Operating time (90°/sec)		Motor rating (W)	Rated current (A) 60Hz				Number of handle turns	Weight		Valve application range (10K)
							1-phase (AC)			DC		kg	lbs	
		Nm	lbf.ft	50 Hz	60 Hz	DC motor	24 V	110 V	220 V	24 V				
SA005L	PCU	50	37	17	14	1.8	1.8	0.35	0.23	1.8	6	3.2	7.1	BFV: ~65A BV: ~32A
SA009L	PCU	90	66	32	26	2.0	-	0.8	0.51	2.25	6	4.3	9.5	BFV: ~100A BV: ~50A

## Optional extras

AC24V	Control board for 24 VAC power supply
EXP	Output the actuator position signal as a resistance value 1 kg

**PCU board**

The Proportional Control Unit (PCU) operates until the current open and close status becomes the same as the value set by the external control system. It provides the function of outputting and transmitting a 4-20 mA signal in proportion to the current position status (0-100%).

**Deadband**

The actuator tries to stop at the exact position based on the set value, but to prevent hunting, a range of dead zones is set which allow the actuator to repeatedly open and close while trying to reach the exact position due to the mechanical inertia of the motor or valve. ( $\pm 0.3$  mA)

**Delay time**

The input signal may be affected by momentary noise or external frequencies. The delay time is set (min 0.5 sec) to prevent hunting phenomenon caused by operating with the same signal input for a certain period of time.

**Auto scan**

The auto scan function automatically operates from the fully closed position to the fully open position with a 2-second press, and saves each position.

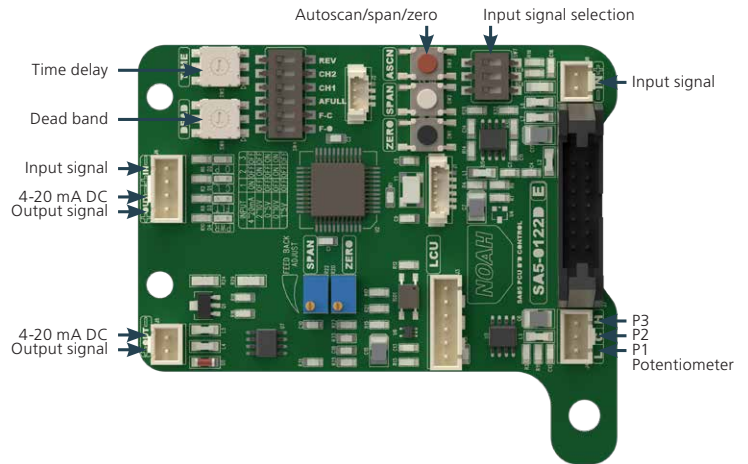

**Power board**

This board converts power from an external source for use by the actuator to operate the PCU board.

**Potentiometer**

Responsible for the resolution of the actuator by using 0-1 k $\Omega$  and plays a role in recognising the current position value. (Optional 135  $\Omega$ )

**Standard wiring diagram**

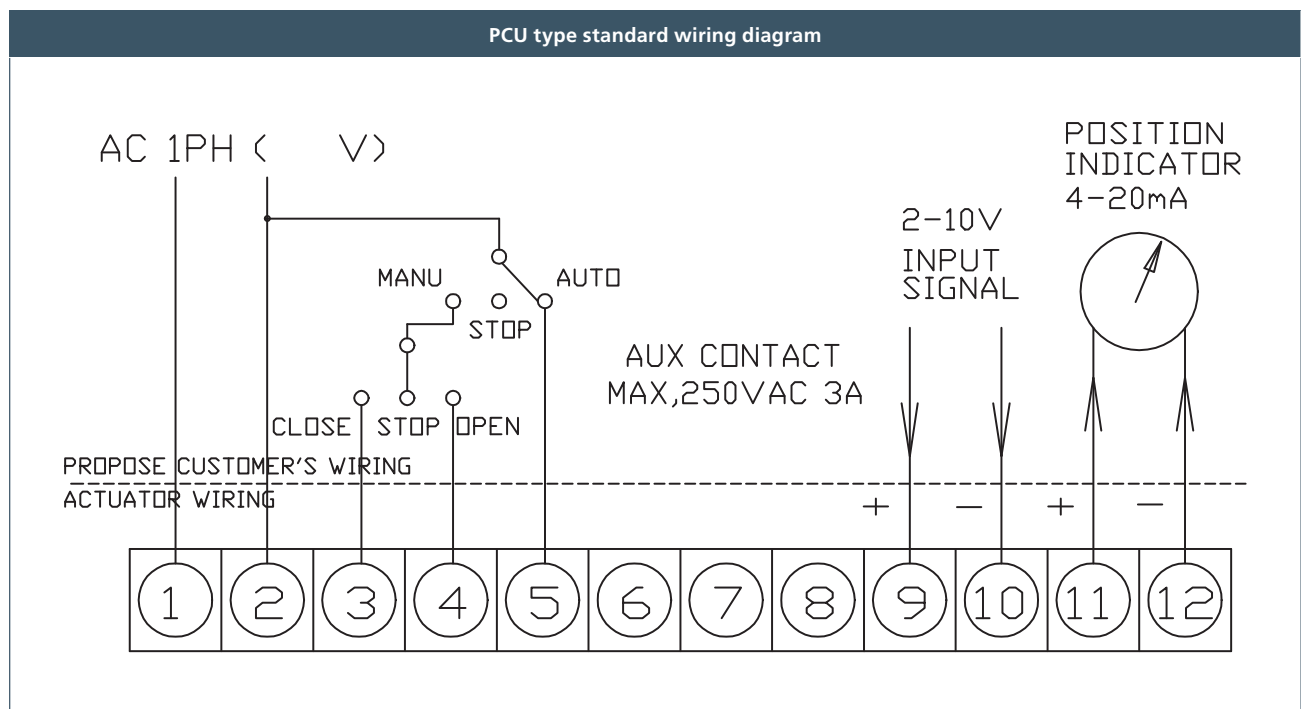

## Standard specifications



Indicator	Dome type (no LED)
Waterproof rating	Waterproof ingress protection IP67
Operating temperature range	Tamb -20 to +70 °C (-4 to +158 °F)
Power supply	110 VAC / 220 VAC 50/60 Hz / AC/DC 24V
Limit switch	2ea Open/Close + 2ea Open/Close (250 VAC) Non-voltage contacts
Travel angle	90° ±5°
Self locking	Prevention of reverse rotation by two-stage worm gear
Manual override	Using an L-shaped wrench (6 mm hex)
Cable entries	Cable line provided
Heater	5 W
Case material	Aluminium
Lubricant	Shell Gadus S2 V220 2
Surface treatment	Anodising
Standard stamp	Polyester powder coating (TGIC-free)

## Super Capacitor (SCP) actuator

The SCP model can be driven to a position set by the user using the built-in super capacitor when the power is turned off. Only one of the driving directions is possible among OPEN/CLOSE/STOP, and the user can set it to the desired position.

When the charging LED lamp blinks, the super capacitor must be charged, and when charging is complete, the charging LED lamp blinks.

## Performance data

Model	Torque		Operating time (90°/sec)	Rated current (A) 60Hz				Motor rating (W)	Number of handle turns	Weight	
				1-Phase (AC)			DC				
	Nm	lbf.ft		50 Hz	24 V	110 V	220 V	24 V		DC motor	kg
SA005L	50	37	8	2.25	1.2	0.8	0.51	15	6	4.3	9.5
SA009L	90	66	13	2.25	1.2	0.8	0.51	15	4.5	4.3	9.5

## Optional extras

EXP	Explosion proof specification / Exd IB T6
-----	---

Internal capacitor specifications



Number of emergency drives	18÷ (Open to Close / Close to Open)	
Charging voltage	26.5 V	
Charging time	24/48 VDC: 2 minutes 15 seconds, 110/220 V: 4 minutes 30 seconds	
Current when charging	24 VDC	2.4 A
	48 VDC	1.3 A
	110 V	1 A
	220 V	0.6 A

\*Recommended for use after buffering. If the buffer is not there, the emergency drive may not work.

Standard wiring diagram

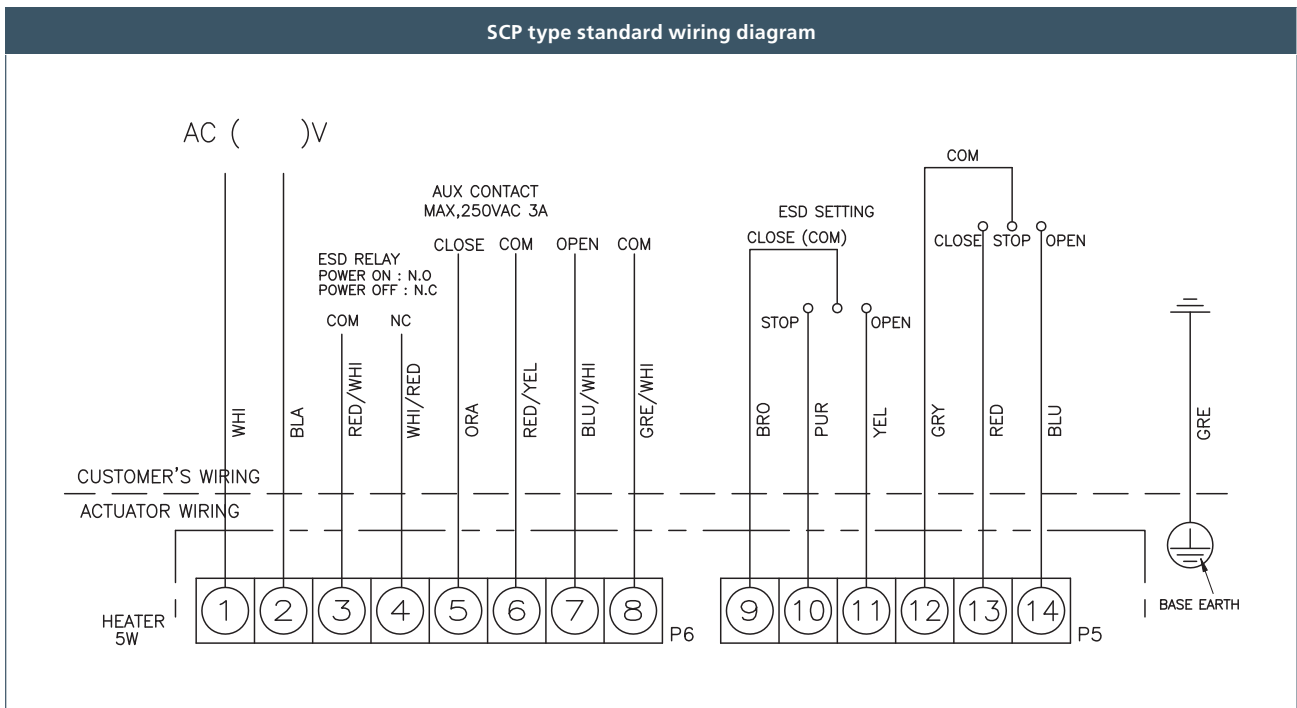

# Dimensional Data

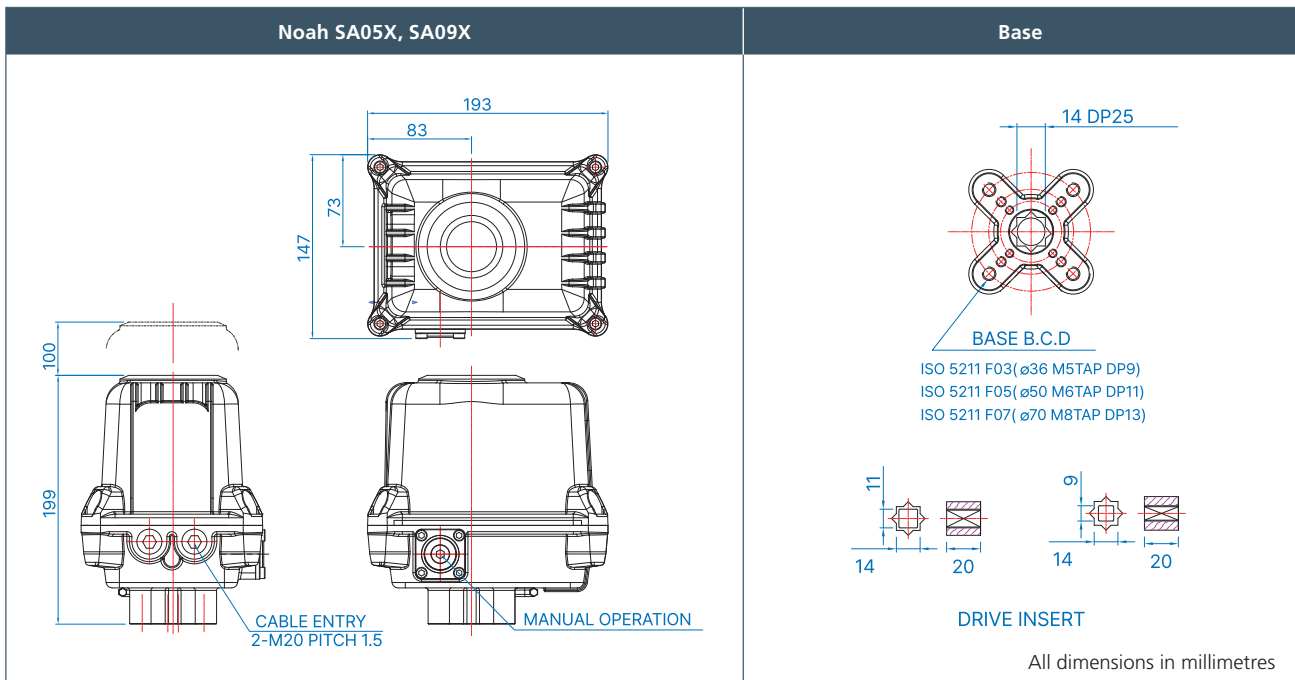
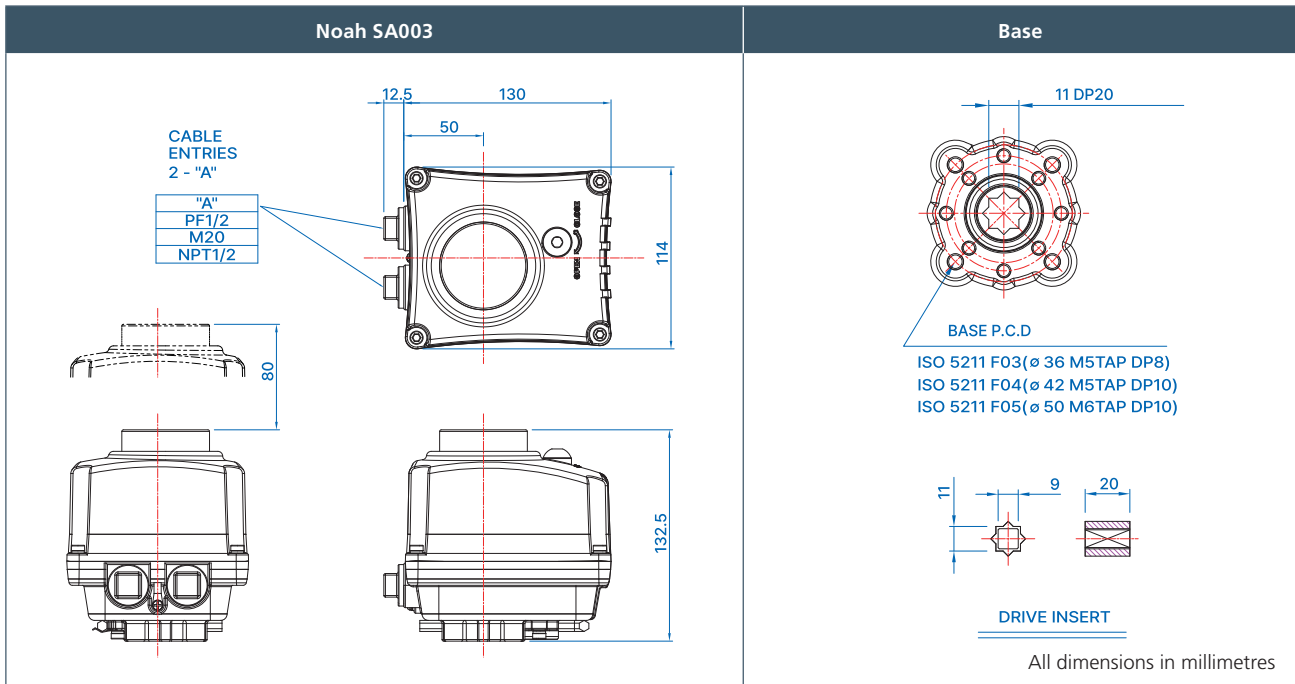

# Dimensional Data

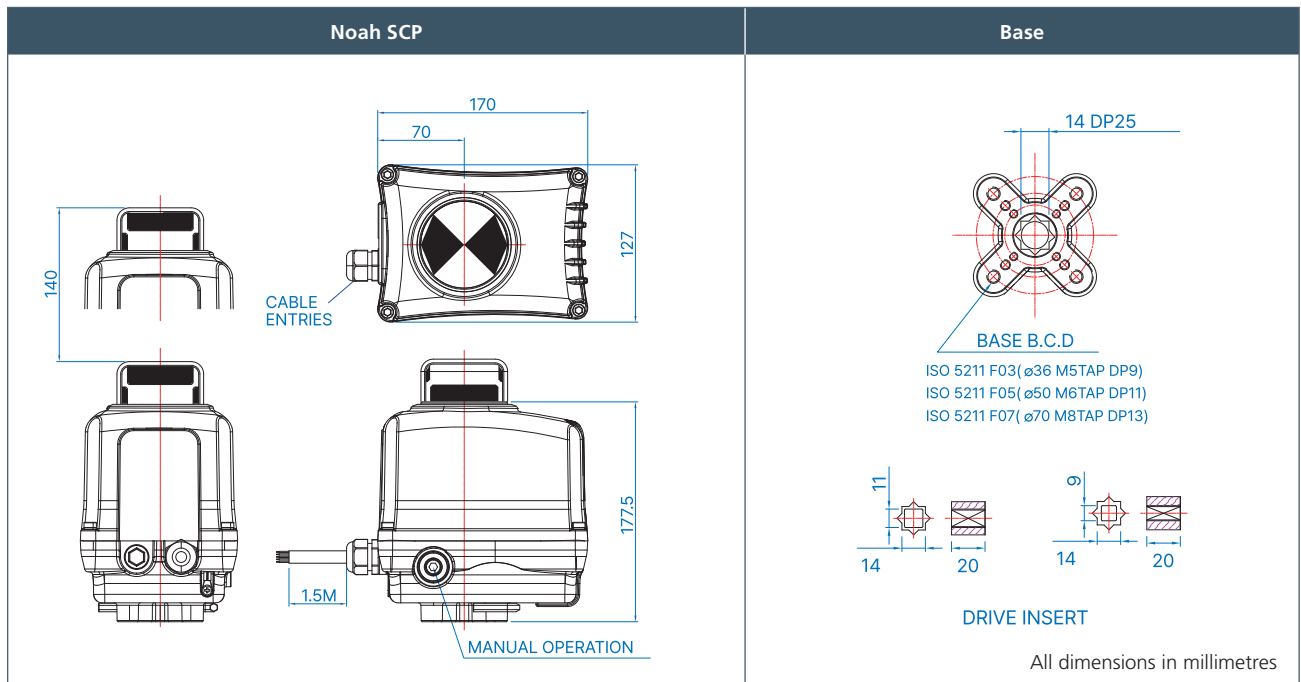
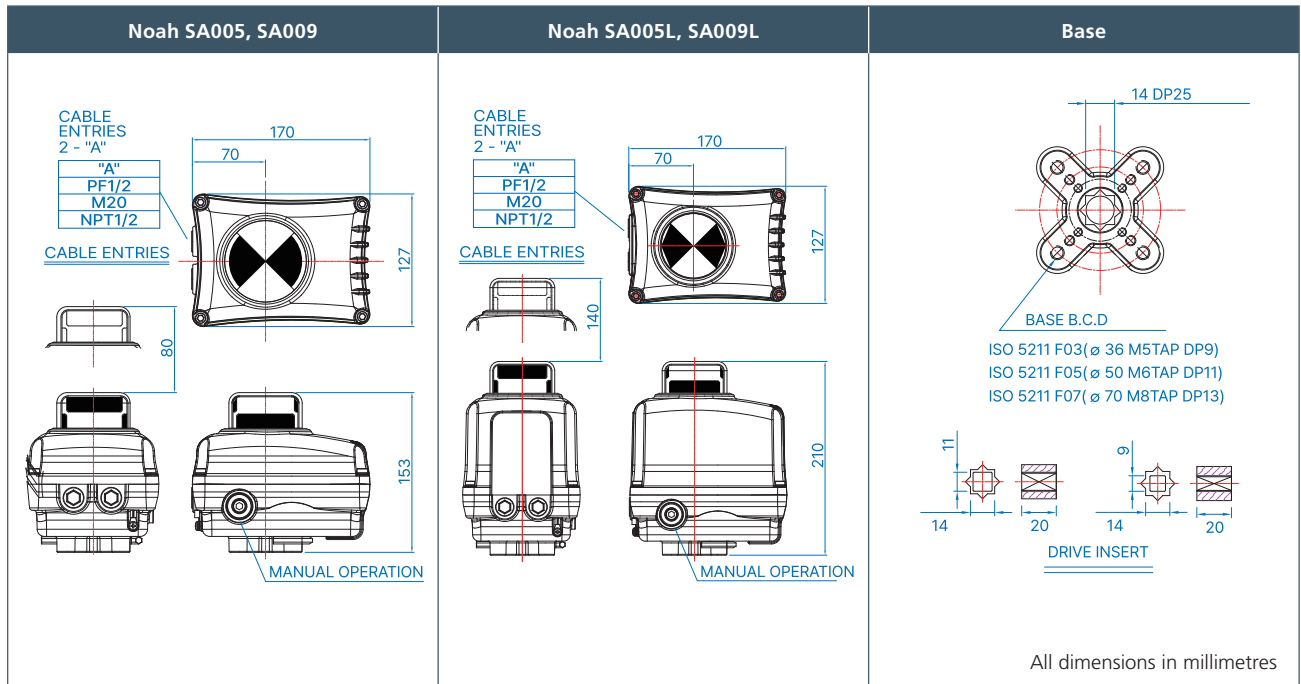



**Contact us now**

[mail@rotork.com](mailto:mail@rotork.com)

[www.rotork.com](http://www.rotork.com)

PUB195-003-00

Issue 10/25