

FINE CONTROLS (UK) LTD



Fine Controls have been supplying process controls & instrumentation equipment since 1994, & now serves an ever expanding customer base, both in the UK & globally.

We offer a full range of valve & instrumentation products & services, with our product range representing leading technologies & brands:

Flow: Flow Meters & Transmitters, Flow Switches, Flow Control Valves & Batch Control Systems

Temperature: Temperature Probes & Thermowells, Temperature transmitters, Temperature Regulators & Temperature Displays

Level: Level Transmitters & Switches

Pressure: Pressure Gauges & Transmitters, Precision & High Pressure Regulators & I-P Converters, Volume boosters.

Precision Pneumatics: Pressure Regulators, I-P Converters, Volume Boosters, Vacuum Regulators

Valves: Solenoid & Pneumatic Valves, Control Valves & Positioners, Actuated Ball, Globe or Diaphragm Valves & Isolation Valves

Services: Repair, Calibration, Panel Build, System Design & Commissioning

A rotork® Brand
FAIRCHILD



bürkert



SIEMENS



alcon
SOLENOID VALVES

A rotork® Brand



MIDLAND-ACS
A rotork® Brand



Honeywell



Bourdon
Baumer Group



SOLDO
CONTROLS

A rotork® Brand



Fine Controls (UK) LTD, Bassendale Road, Croft Business Park,
Bromborough, Wirral, CH62 3QL UK
Tel: 0151 343 9966
Email: sales@finecontrols.com

Fairchild Model 17 Vacuum Regulator

Installation, Operation and Maintenance Instructions

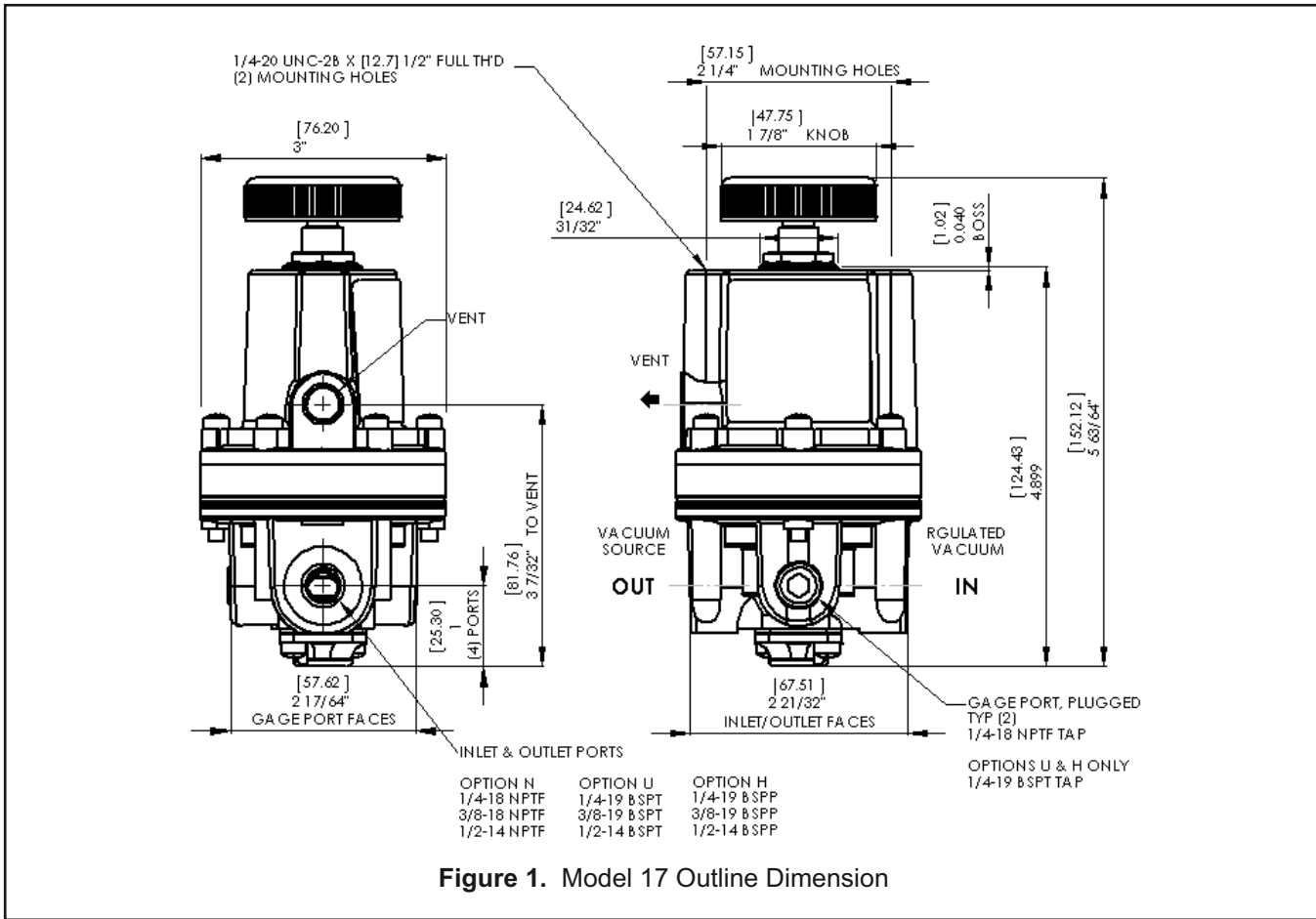

General Information

The Model 17 is a high accuracy vacuum regulator that provides uniform vacuum regulation independent of vacuum supply changes and flow demand.

Specifications

Vacuum Supply (Max)	30" Hg (Full Vacuum)
Flow Capacity	3 scfm @ 25" Hg Supply, 10" Hg setpoint
Sensitivity	1/8" W. C.
Ambient Temperature Limits	-40 F to + 200°F, (-40°C to + 93.2°C)
Vacuum Supply Effect	Less than 0.1" Hg for 10" Hg change in vacuum supply
Materials of Construction	Body & Housing Aluminum Trim Brass, Zinc Plated Steel Elastomers Nitrile

Installation

Clean all pipelines to remove dirt and scale before installation.

Apply a minimum amount of pipe compound to the male threads of the fitting only. Start with the third thread back and work away from the end of the fitting to avoid the possibility of contaminating the regulator. Install the regulator in the air line.

The inlet and outlet connections are labeled on the underside of the regulator with the arrows pointing in the direction of the flow. Tighten connections securely.

Avoid undersized fittings that will limit the flow through the regulator and cause a pressure drop downstream. For more information, see Figure 1. "Outline Dimensions".

NOTE: Oil free air must be applied to the regulator. Use a filter to remove dirt and entrained liquid in the air line ahead of the regulator. If an air line lubricator is used, it MUST be located downstream of the regulator, to avoid interference with regulator performance.

Maintenance

To clean the Model 10V, use the following procedures:

1. Before assembly, shut off the valve that is supplying air to the regulator. This is to prevent air from escaping. **It is not necessary to remove the regulator from the air line.**
2. Remove the two Screws from the bottom of the unit.
3. Pull out the Inner Valve Assembly. Wash the Seat on the Inner Valve Assembly carefully.
4. Wipe off any particles that may be attached to rubber Seat Ring in Body.
5. Replace the assembly carefully.
6. Keep the vent hole in the Bonnet clear for proper regulator operation. Lubricate the adjusting screw with Molycote "G".

NOTE: Avoid such solvents as acetone, carbon tetrachloride and trichorethylene.

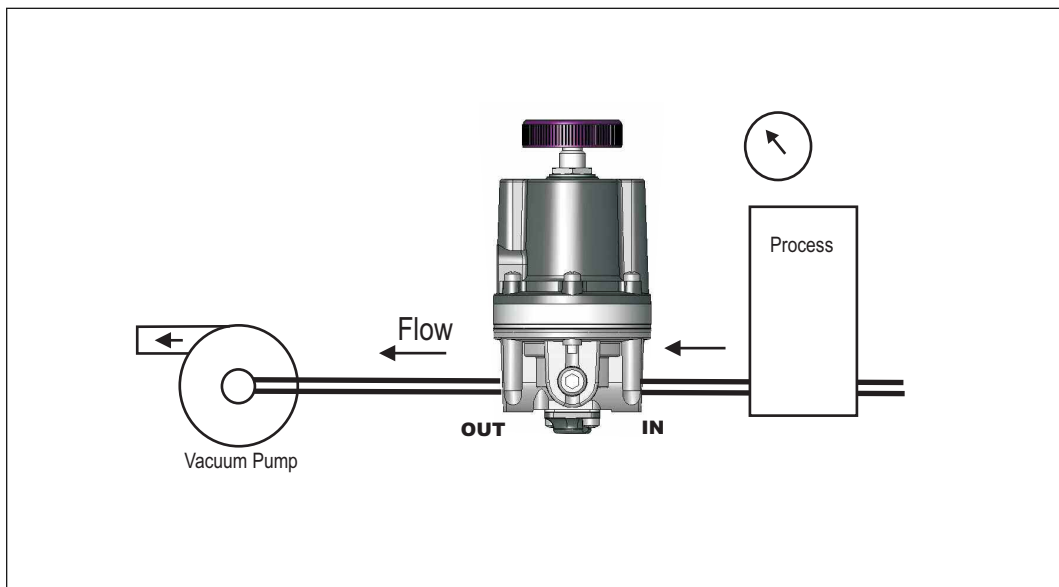

Figure 2. Model 17 Installation Diagram

LEGAL NOTICE

The information set forth in the foregoing Installation, Operation and Maintenance Instructions shall not be modified or amended in any respect without prior written consent of Fairchild Industrial Products Company. In addition, the information set forth herein shall be furnished with each product sold incorporating Fairchild's unit as a component thereof.



Trouble-Shooting	
Problem	Solution
Leakage	Body Screws Tightness. Diaphragms.
Valve Chatter	Seal Ring lubrication.