

# Temperature Measurement

## Transmitter for field mounting/field indicator

SITRANS TF - Transmitter, two-wire system and  
SITRANS TF - Field indicator for 4 to 20 mA

### Overview



#### Our field devices for heavy industrial use

- HART, Universal
- 4 to 20 mA, universal
- Field indicator for 4 to 20 mA signals

The temperature transmitter SITRANS TF works where others feel uncomfortable.

### Benefits

- Universal use
  - as transmitter for resistance thermometer, thermocouple element,  $\Omega$  or mV signal
  - as field indicator for any 4 to 20 mA signals
- Local sensing of measured values over digital display
- Rugged two-chamber enclosure in die-cast aluminium or stainless steel
- Degree of protection IP67
- Test terminals for direct read-out of the output signal without breaking the current loop
- Can be mounted elsewhere if the measuring point
  - is hard to access,
  - is subject to high temperatures,
  - is subject to vibrations from the system,
  - or if you want to avoid long neck tubes and/or protective tubes.
- Can be mounted directly on American-design sensors
- Wide range of approvals for use in potentially explosive atmospheres. "Intrinsically safe, non-sparking and flameproof" type of protections, for Europe and USA.
- SIL2 (with order code C20), SIL2/3 (with C23)

### Application

SITRANS TF can be used everywhere where temperatures need to be measured under particularly adverse conditions, or where a convenient local display is ideal. Which is why users from all industries have opted for this field device. The rugged enclosure protects the electronics. The stainless steel model is almost completely resistant to sea water and other aggressive elements. The inner workings offer high measuring accuracy, universal input and a wide range of diagnostic options.

### Function

#### Configuration

The communication capability over the HART protocol V 5.9 of the SITRANS TF with an integrated SITRANS TH300 permits parameterization using a PC or HART communicator (hand-held communicator). The SIMATIC PDM makes it easy.

Parameterization is carried out using a PC for SITRANS TF with the integrated and programmable SITRANS TK. Available for this purpose are a special modem and the software tool SIPROM T.

#### Mode of operation

##### Mode of operation of SITRANS TF as temperature transmitter

The sensor signal, whether resistance thermometer, thermocouple element or  $\Omega$  or mV signal, is amplified and linearized. Sensor and output side are electrically isolated. An internal cold junction is integrated for measurements with thermocouple elements.

The device outputs a temperature-linear direct current of 4 to 20 mA. As well as the analog transmission of measured values from 4 to 20 mA, the HART version also supports digital communication for online diagnostics, measured value transmission and configuration.

SITRANS TF automatically detects when a sensor should be interrupted or is indicating a short-circuit. The practical test terminals allow direct measurement of 4 to 20 mA signals over an ammeter without interrupting the output current loop.

##### Mode of operation of SITRANS TF as field indicator

Any 4 to 20 mA signal can be applied to the generous terminal block. As well as a range of predefined measurement units, the adjustable indicator also supports the input of customized units. This means that any 4 to 20 mA signal can be represented as any type of unit, e.g. pressure, flow rate, filling level or temperature.

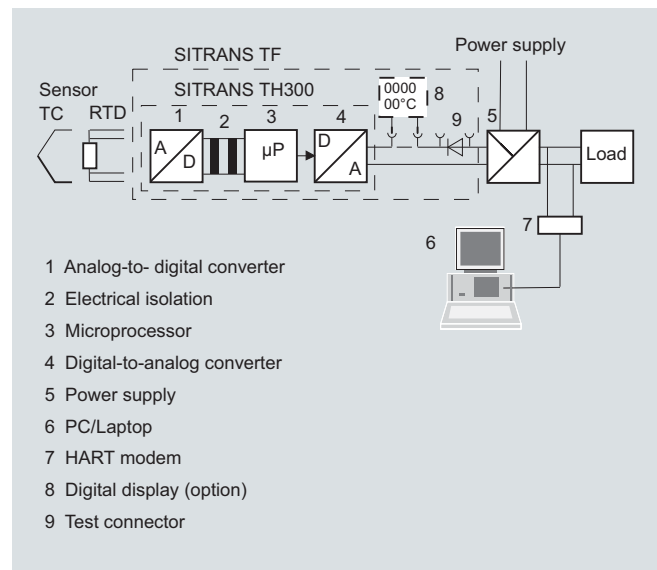

Mode of operation: SITRANS TF with integrated transmitter and digital display

# Temperature Measurement

## Transmitter for field mounting/field indicator

SITRANS TF - Transmitter, two-wire system and  
SITRANS TF - Field indicator for 4 to 20 mA

### Technical specifications

#### Input

##### Resistance thermometer

Measured variable	Temperature
Sensor type	
• to IEC 60751	Pt25 ... Pt1000
• to JIS C 1604; a=0.00392 K-1	Pt25 ... Pt1000
• to IEC 60751	Ni25 ... Ni1000
Units	°C and °F
Connection	
• Normal connection	1 resistance thermometer (RTD) in 2-wire, 3-wire or 4-wire system
• Generation of average value	Series or parallel connection of several resistance thermometers in a two-wire system for the generation of average temperatures or for adaptation to other device types
• Generation of difference	2 resistance thermometers (RTD) in 2-wire system (RTD 1 – RTD 2 or RTD 2 – RTD 1)
Interface	
• Two-wire system	Parameterizable line resistance $\leq 100 \Omega$ (loop resistance)
• Three-wire system	No balancing required
• Four-wire system	No balancing required
Sensor current	$\leq 0.45$ mA
Response time	$\leq 250$ ms for 1 sensor with open-circuit monitoring
Open-circuit monitoring	Always active (cannot be disabled)
Short-circuit monitoring	can be switched on/off (default value: ON)
Measuring range	parameterizable (see table "Digital measuring errors")
Min. measured span	10 °C (18 °F)
Characteristic curve	Temperature-linear or special characteristic

##### Resistance-based sensors

Measured variable	Actual resistance
Sensor type	Resistance-based, potentiometers
Units	$\Omega$
Connection	
• Normal connection	1 resistance-based sensor (R) in 2-wire, 3-wire or 4-wire system
• Generation of average value	2 resistance-based sensors in 2-wire system for generation of average value
• Generation of difference	2 resistance-based sensor in 2-wire system (R 1 – R 2 or R 2 – R 1)
Interface	
• Two-wire system	Parameterizable line resistance $\leq 100 \Omega$ (loop resistance)
• Three-wire system	No balancing required
• Four-wire system	No balancing required
Sensor current	$\leq 0.45$ mA
Response time	$\leq 250$ ms for 1 sensor with open-circuit monitoring
Open-circuit monitoring	Can be switched off
Short-circuit monitoring	Can be switched off (value is adjustable)

#### Measuring range

#### Min. measured span

#### Characteristic curve

#### Thermocouples

#### Measured variable

#### Sensor type (thermocouples)

- Type B
- Type C
- Type D
- Type E
- Type J
- Type K
- Type L
- Type N
- Type R
- Type S
- Type T
- Type U

#### Units

#### Connection

- Normal connection
- Generation of average value
- Generation of difference

#### Response time

#### Open-circuit monitoring

#### Cold junction compensation

- Internal
- External
- External fixed

#### Measuring range

#### Min. measured span

#### Characteristic curve

#### mV sensor

#### Measured variable

#### Sensor type

#### Units

#### Response time

#### Open-circuit monitoring

#### Measuring range

#### Min. measured span

#### Overload capability of the input

#### Input resistance

#### Characteristic curve

parameterizable max. 0 ... 2200  $\Omega$  (see table "Digital measuring errors")

5 ... 25  $\Omega$  (see Table "Digital measuring errors")

Resistance-linear or special characteristic

Temperature

Pt30Rh-Pt6Rh to DIN IEC 584  
W5 %-Re acc. to ASTM 988  
W3 %-Re acc. to ASTM 988  
NiCr-CuNi to DIN IEC 584  
Fe-CuNi to DIN IEC 584  
NiCr-Ni to DIN IEC 584  
Fe-CuNi to DIN 43710  
NiCrSi-NiSi to DIN IEC 584  
Pt13Rh-Pt to DIN IEC 584  
Pt10Rh-Pt to DIN IEC 584  
Cu-CuNi to DIN IEC 584  
Cu-CuNi to DIN 43710

°C or °F

1 thermocouple (TC)

2 thermocouples (TC)

2 thermocouples (TC)  
(TC 1 – TC 2 or TC 2 – TC 1)

$\leq 250$  ms for 1 sensor with open-circuit monitoring

Can be switched off

With integrated Pt100 resistance thermometer

With external Pt100 IEC 60751 (2-wire or 3-wire connection)

Cold junction temperature can be set as fixed value

parameterizable (see table "Digital measuring errors")

Min. 40 ... 100 °C (72 ... 180 °F) (see table "Digital measuring errors")

Temperature-linear or special characteristic

DC voltage

DC voltage source (DC voltage source possible over an externally connected resistor)

mV

$\leq 250$  ms for 1 sensor with open-circuit monitoring

Can be switched off

-10 ... +70 mV  
-100 ... +1100 mV

2 mV or 20 mV

-1.5 ... +3.5 V DC

$\geq 1$  M $\Omega$

Voltage-linear or special characteristic

# Temperature Measurement

## Transmitter for field mounting/field indicator

SITRANS TF - Transmitter, two-wire system and  
SITRANS TF - Field indicator for 4 to 20 mA

<b>Output</b>	
Output signal	4 ... 20 mA, 2-wire
Communication with SITRANS TH300	acc. to HART Rev. 5.9
<b>Digital display</b>	
Digital display (optional)	In current loop
Display	Max. 5 digits
Digit height	9 mm (0.35")
Display range	-99 999 ... + 99 999
Units	any (max. 5 char.)
Setting: Zero point, full-scale value and unit	with 3 buttons
Load voltage	2.1 V
<b>Measuring accuracy</b>	
Digital measuring errors	See table "Digital measuring errors"
Reference conditions	
• Auxiliary power	24 V ± 1 %
• Load	500 Ω
• Ambient temperature	23 °C (73.4 °F)
• Warming-up time	> 5 min
Error in the analog output (digital/analog converter)	< 0.025 % of span
Error due to internal cold junction	< 0.5 °C (0.9 °F)
Influence of ambient temperature	
• Analog measuring error	0.02 % of span/10 °C (18 °F)
• Digital measuring errors	
- with resistance thermometers	0.06 °C (0.11 °F)/10°C (18 °F)
- with thermocouples	0.6 °C (1.1 °F)/10°C (18 °F)
Auxiliary power effect	< 0.001 % of span/V
Effect of load impedance	< 0.002 % of span/100 Ω
Long-term drift	
• In the first month	< 0.02 % of span
• After one year	< 0.3 % of span
• After 5 years	< 0.4 % of span
<b>Conditions of use</b>	
<u>Ambient conditions</u>	
Storage temperature	-40 ... +85 °C (-40 ... +185 °F)
Condensation	Permissible
Electromagnetic compatibility	According to EN 61326 and NAMUR NE21
Degree of protection to EN 60529	IP67
<b>Construction</b>	
Weight	Approx. 1.5 kg (3.3 lb) without options
Dimensions	See "Dimensional drawings"
Enclosure material	Die-cast aluminum, low in copper, GD-AlSi 12 or stainless steel, polyester-based lacquer, stainless steel rating plate
Electrical connection, sensor connection	Screw terminals, cable inlet via M20 x 1.5 or ½-14 NPT screwed gland
Mounting bracket (optional)	Steel, galvanized and chrome-plated or stainless steel

<b>Auxiliary power</b>	
Without digital display	11 to 35 V DC (30 V with Ex)
With digital display	13.1 to 35 V DC (30 V with Ex)
Electrically isolated	Between input and output
• Test voltage	$U_{\text{eff}} = 1 \text{ kV}$ , 50 Hz, 1 min
<b>Certificates and approvals</b>	
Explosion protection ATEX	
• "Intrinsic safety" type of protection	with digital display: II 2 (1) G EEx ia IIC T4 without digital display: II 2 (1) G EEx ia IIC T6
- EC type test certificate	ZELM 99 ATEX 0007
• "Operating equipment that is non-ignitable and has limited energy for zone 2" type of protection	II 3G EEx nAL IIC T6/T4
- EC type test certificate	ZELM 99 ATEX 0007
• "Flame-proof enclosure" type of protection	II 2 G EEx d IIC T5/T6 II 1D Ex tD A20 IP65 T100 °C, T85 °C
- EC type test certificate	CESI 99 ATEX 079
Explosion protection to FM	
• Identification (XP, DIP, NI, S)	Certificate of Compliance 3017742
	• XP/II/1/BCD/T5 Ta = 85 °C (185 °F), T6 Ta = 50 °C (112 °F), Type 4X
	• DIP/II, III/1/EFG/T5 Ta = 85 °C (185 °F), T6 Ta = 50 °C (112 °F), Type 4X
	• NI/II/2/ABCD/T5 Ta = 85 °C (185 °F), T6 Ta = 50 °C (112 °F), Type 4X
	• S/II, III/2/FG/T5 Ta = 85 °C (185 °F), T6 Ta = 50 °C (112 °F), Type 4X
Other certificates	GOST
<b>Hardware and software requirements</b>	
• For the parameterization software SIPROM T for SITRANS TH200	
- Personal computer	PC with CD-ROM drive and USB/RS 232 interface
- PC operating system	Windows 98, NT, 2000, XP
• For the parameterization software SIMATIC PDM for SITRANS TH300	See chapter 9 "Software", "SIMATIC PDM"
<b>Communication</b>	
Load for HART connection	230 ... 1100 Ω
• Two-core shielded	≤ 3.0 km (1.86 mi)
• Multi-core shielded	≤ 1.5 km (0.93 mi)
Protocol	HART protocol, version 5.9

### Factory setting (transmitter):

- Pt100 (IEC 751) with 3-wire circuit
- Measuring range: 0 ... 100 °C (32 ... 212 °F)
- Error signal in the event of sensor breakage: 22.8 mA
- Sensor offset: 0 °C (0 °F)
- Damping 0.0 s

# Temperature Measurement

## Transmitter for field mounting/field indicator

SITRANS TF - Transmitter, two-wire system and  
SITRANS TF - Field indicator for 4 to 20 mA

### Digital measuring errors

#### Resistance thermometer

Input	Measuring range °C / (°F)	Min. mea- sured span		Digital accu- racy	
		°C	(°F)	°C	(°F)
<b>to IEC 60751</b>					
Pt25	-200 ... +850 (-328 ... +1562)	10	(18)	0.3	(0.54)
Pt50	-200 ... +850 (-328 ... +1562)	10	(18)	0.15	(0.27)
Pt100 ... Pt200	-200 ... +850 (-328 ... +1562)	10	(18)	0.1	(0.18)
Pt500	-200 ... +850 (-328 ... +1562)	10	(18)	0.15	(0.27)
Pt1000	-200 ... +350 (-328 ... +662)	10	(18)	0.15	(0.27)
<b>to JIS C1604-81</b>					
Pt25	-200 ... +649 (-328 ... +1200)	10	(18)	0.3	(0.54)
Pt50	-200 ... +649 (-328 ... +1200)	10	(18)	0.15	(0.27)
Pt100 ... Pt200	-200 ... +649 (-328 ... +1200)	10	(18)	0.1	(0.18)
Pt500	-200 ... +649 (-328 ... +1200)	10	(18)	0.15	(0.27)
Pt1000	-200 ... +350 (-328 ... +662)	10	(18)	0.15	(0.27)
Ni 25 to Ni1000	-60 ... +250 (-76 ... +482)	10	(18)	0.1	(0.18)

#### Resistance-based sensors

Input	Measuring range Ω	Min. mea- sured span Ω	Digital accu- racy Ω
Resistance	0 ... 2200	25	0.25

### Thermocouples

Input	Measuring range °C / (°F)	Min. mea- sured span		Digital accu- racy	
		°C	(°F)	°C	(°F)
Type B	0 ... 1820 (32 ... 3308)	100	(180)	2 <sup>1)</sup>	(3.6) <sup>1)</sup>
Type C (W5)	0 ... 2300 (32 ... 4172)	100	(180)	1 <sup>2)</sup>	(1.8) <sup>2)</sup>
Type D (W3)	0 ... 2300 (32 ... 4172)	100	(180)	1 <sup>2)</sup>	(1.8) <sup>2)</sup>
Type E	-200 ... +1000 (-328 ... +1832)	50	(90)	1	(1.8)
Type J	-210 ... +1200 (-346 ... +2192)	50	(90)	1	(1.8)
Type K	-200 ... +1370 (-328 ... +2498)	50	(90)	1	(1.8)
Type L	-200 ... +900 (-328 ... +1652)	50	(90)	1	(1.8)
Type N	-200 ... +1300 (-328 ... +2372)	50	(90)	1	(1.8)
Type R	-50 ... +1760 (-58 ... +3200)	100	(180)	2	(3.6)
Type S	-50 ... +1760 (-58 ... +3200)	100	(180)	2	(3.6)
Type T	-20 ... +400 (-328 ... +752)	40	(72)	1	(1.8)
Type U	-200 ... +600 (-328 ... +1112)	50	(90)	2	(3.6)

1) The digital accuracy in the range 0 to 300 °C (32 to 572 °F) is 3 °C (5.4 °F).

2) The digital accuracy in the range 1750 to 2300 °C (3182 to 4172 °F) is 2 °C (3.6 °F).

#### mV sensor

Input	Measuring span mV	Min. mea- sured span mV	Digital accu- racy μV
mV sensor	-100 ... +1100	20	400

The digital accuracy is the accuracy after the analog/digital conversion including linearization and calculation of the measured value.

An additional error is generated in the output current 4 to 20 mA as a result of the digital/analog conversion of 0.025 % of the set span (digital-analog error).

The total error under reference conditions at the analog output is the sum from the digital error and the digital-analog error (poss. with the addition of cold junction errors in the case of thermocouple measurements).

# Temperature Measurement

## Transmitter for field mounting/field indicator

SITRANS TF - Transmitter, two-wire system and  
SITRANS TF - Field indicator for 4 to 20 mA

3

Selection and Ordering data	Order No.
<b>Temperature transmitter in field housing</b> Two-wire system 4 ... 20 mA, with electrical isolation, with documentation on CD-ROM	7 NG 3 1 3 - - - - -
<b>Integrated transmitter</b>	
• SITRANS TH200, programmable	
- without Ex protection D)	5 0
- with EEx ia D)	5 1
- with EEx nAL for zone 2 D)	5 2
- total device SITRANS TF EEx d <sup>1)</sup> D)	5 4
- total device SITRANS TF according to FM (XP, DIP, NI, S) <sup>1)</sup> D)	5 5
• SITRANS TH300, communication capability according to HART V 5.9	
- without Ex-protection D)	6 0
- with EEx ia D)	6 1
- with EEx nAL for zone 2 D)	6 2
- total device SITRANS TF EEx d <sup>1)</sup> D)	6 4
- total device SITRANS TF according to FM (XP, DIP, NI, S) <sup>1)</sup> D)	6 5
<b>SITRANS TF field indicator</b> for 4 ... 20 mA signals, with documentation on CD-ROM	7 NG 3 1 3 - - - - -
• without Ex-protection	0 0 1
• with EEx ia	0 1 1
• with EEx nAL for zone 2	0 2 1
• total device SITRANS TF EEx d <sup>1)</sup>	0 4 1
• total device SITRANS TF according to FM (XP, DIP, NI, S) <sup>1)</sup>	0 5 1
<b>Enclosure</b>	
• die-cast aluminium	A
• stainless steel precision casting	E
<b>Connections/cable inlet</b>	
• screwed glands M20x1.5	B
• screwed glands ½-14 NPT	C
<b>Digital indicator</b>	
• without	0
• with	1
<b>Mounting bracket and securing parts</b>	
• without	0
• made of steel	1
• made of stainless steel	2
<b>Further designs</b>	Order code
Please add "-Z" to Order No. and specify Order code(s) and plain text.	
<b>Customer-specific setting of operating data</b>	Y 0 1 <sup>2)</sup>
<b>Inscription on measuring-point label (TAG plate)</b>	
• measuring range (max. 27 characters)	Y 2 2 <sup>3)</sup>
• meas. point description (max. 16 char.)	Y 2 3 <sup>3)</sup>
• measuring point text (max. 27 char.)	Y 2 4 <sup>3)</sup>
<b>Test protocol (5 measuring points)</b>	C 1 1 <sup>4)</sup>
<b>Functional safety SIL2</b>	C 2 0 <sup>5)</sup>
<b>Functional safety SIL2/3</b>	C 2 3 <sup>5)</sup>
<b>Explosion protection</b>	
Explosion protection EEx ia to INMERTO (Brazil) (only with 7NG313.-1....)	E 2 5
Explosion protection EEx d to INMERTO (Brazil) (only with 7NG313.-4....)	E 2 6

Supply units see Chap. 8 "Supplementary Components".

1) Without cable gland.

2) Y01: Please specify all data that does not correspond to factory settings (see above) (e.g. Y01 = thermocouple element type K; internal cold junction; 0 ... 800 °C; fault current 3.6 mA).

3) Y22, Y23, Y24: If no order is placed for Y01, these data are only noted on the measuring point label and are not programmed in the transmitter.

4) Can only be ordered together with Y01.

5) Only with 7NG3135-... and 7NG3136-...

Selection and Ordering data	Order No.
<b>Accessories</b>	
<b>Modem for SITRANS TH100, TH200 and TR200 incl. parameterization software T</b>	
• with USB interface	▶ 7NG3092-8KU
<b>CD for measuring instruments for temperature</b>	▶ A5E00364512
with documentation in German, English, French, Spanish, Italian and Portuguese, and parameterization software SIPROM T (included in delivery with SITRANS TF)	
<b>HART modem</b>	
• with RS 232 interface	▶ 7MF4997-1DA D)
• with USB interface	▶ 7MF4997-1DB D)
<b>SIMATIC PDM parameterization software</b> also for SITRANS TH300	see chap. 9
<b>Mounting bracket and securing parts</b>	
• made of steel for 7NG313.-.B..	7MF4997-1AC
• made of steel for 7NG313.-.C..	7MF4997-1AB
• made of stainless steel for 7NG313.-.B..	▶ 7MF4997-1AJ
• made of stainless steel for 7NG313.-.C..	7MF4997-1AH
<b>Digital indicator<sup>1)</sup></b>	7MF4997-1BS
<b>Connection board</b>	A5E02226423

▶ Available ex stock.

Supply units see Chap. 8 "Supplementary Components".

1) It is not possible to upgrade devices with Ex protection

D) Subject to export regulations AL: N, ECCN: EAR99H.

### Factory setting (transmitter):

- Pt100 (IEC 751) with three-wire circuit
- Measuring range: 0 ... 100 °C (32 ... 212 °F)
- Fault current 22.8 mA
- Sensor offset: 0 °C (0 °F)
- Damping 0.0 s

# Temperature Measurement

## Transmitter for field mounting/field indicator

SITRANS TF - Transmitter, two-wire system and  
SITRANS TF - Field indicator for 4 to 20 mA

### Dimensional drawings

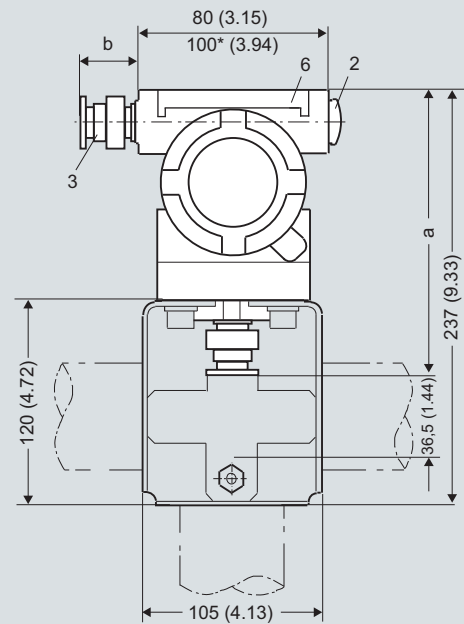
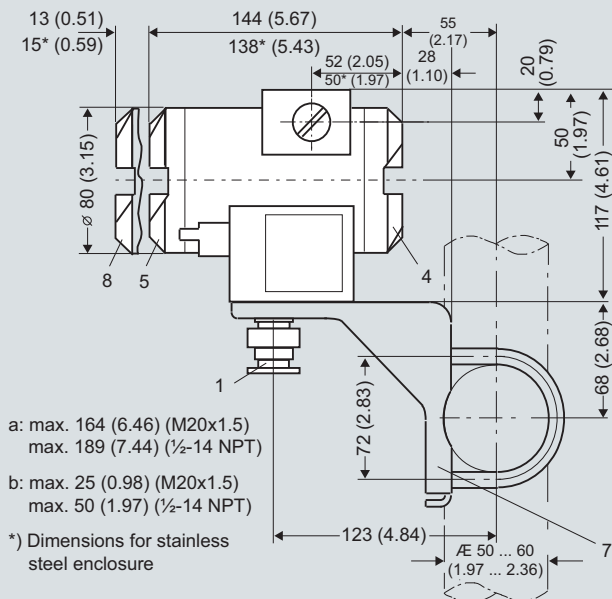

- 1 Sensor connection (screwed gland M20x1,5 or 1/2-14 NPT)
- 2 Blanking plug
- 3 Electrical connection (screwed gland M20x1,5 or 1/2-14 NPT)
- 4 Terminal side, output signal
- 5 Terminal side, sensor

- 6 Protective cover (without function)
- 7 Mounting bracket (option) with clamp for securing to a vertical or horizontal pipe
- 8 Cover with window for digital display

SITRANS TF, dimensions in mm (inches)

# Temperature Measurement Transmitter for field mounting/field indicator

SITRANS TF - Transmitter, two-wire system and  
SITRANS TF - Field indicator for 4 to 20 mA

## Schematics

### Resistance thermometer

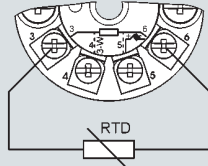

Two-wire system <sup>1)</sup>

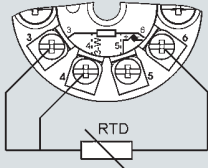

Three-wire system

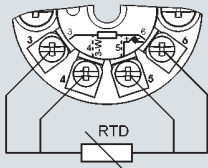

Four-wire system

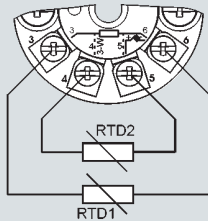

Generation of average value / difference <sup>1)</sup>

<sup>1)</sup> Programmable line resistance for the purpose of correction.

### Resistance

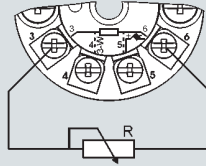

Two-wire system <sup>1)</sup>

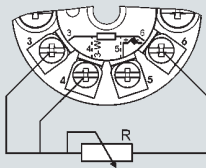

Three-wire system

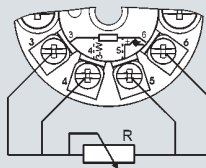

Four-wire system

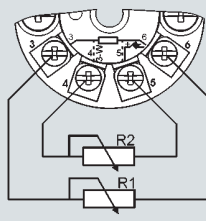

Generation of average value / difference <sup>1)</sup>

### Thermocouple

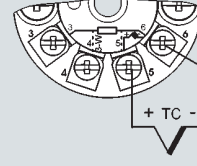

Cold junction compensation  
Internal/fixed value

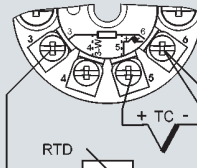

Cold junction compensation with  
external Pt100 in two-wire system <sup>1)</sup>

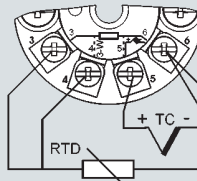

Cold junction compensation with  
external Pt100 in three-wire system

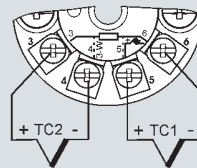

Generation of average value / difference  
with internal cold junction compensation

### Voltage measurement

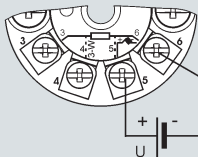

### Current measurement

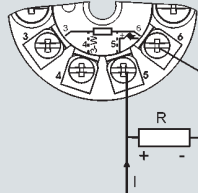

Sensor connection assignment

3

# Temperature Measurement

## Transmitters for field mounting

### SITRANS TF fieldbus transmitter

#### Overview



#### Our field devices for heavy industrial use

- FOUNDATION fieldbus
- PROFIBUS PA

The SITRANS TF temperature transmitter works where others can't cope.

#### Benefits

- For universal use as a transmitter for resistance thermometers, thermocouple elements,  $\Omega$  or mV signals
- Rugged two-chamber enclosure in die-cast aluminium or stainless steel
- Degree of protection IP67
- Can be mounted elsewhere if the measuring point
  - is hard to access,
  - is subject to high temperatures,
  - is subject to vibrations from the system,
  - or if you want to avoid long neck tubes and/or protective tubes.
- Can be mounted directly on American-design sensors
- Wide range of approvals for use in potentially explosive atmospheres. "Intrinsically safe, non-sparking and flameproof" type of protection, for Europe and USA

#### Application

The SITRANS TF can be used everywhere where temperatures need to be measured under particularly harsh conditions. Which is why users from all industries have opted for this field device. The rugged enclosure protects the electronics. The stainless steel model is almost completely resistant to sea water and other aggressive elements. The inner workings offer high measuring accuracy, universal input and a wide range of diagnostic options.

#### Function

##### Features

##### General

- Polarity-neutral bus connection
- 24-bit analog-digital converter for high resolution
- Electrically isolated
- Version for use in hazardous areas
- Special characteristic
- Sensor redundancy

##### Transmitter with PROFIBUS PA communication

- Function blocks: 2 x analog

##### Transmitter with FOUNDATION fieldbus communication

- Function blocks: 2 x analog and 1 x PID
- Functionality: Basic or LAS

##### Mode of operation

The following function diagram explains the mode of operation of the transmitter.

The only difference between the two versions of the SITRANS TF (7NG3137-... and 7NG3138-...) is the type of field bus protocol used (PROFIBUS PA or FOUNDATION fieldbus).

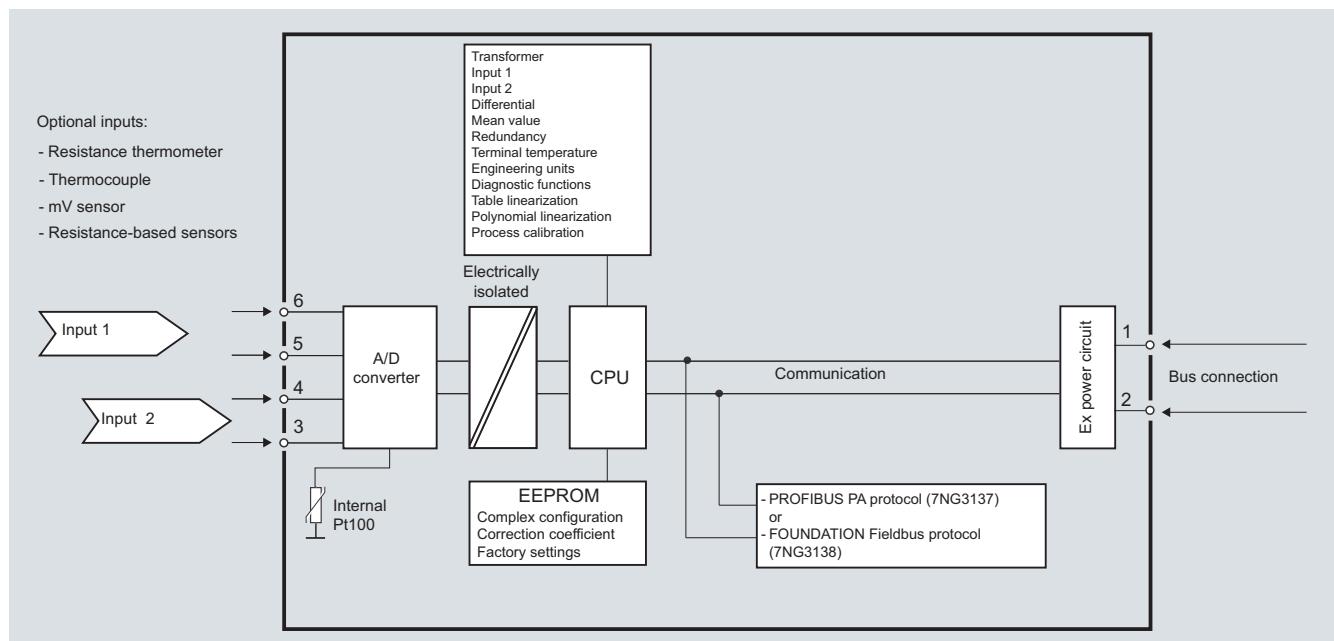

SITRANS TF with TH400, function diagram

# Temperature Measurement

## Transmitters for field mounting

### SITRANS TF fieldbus transmitter

#### System communication

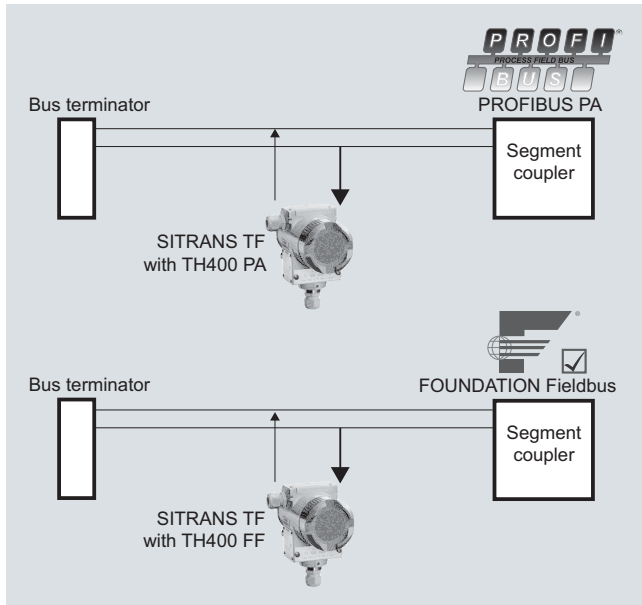

SITRANS TF with TH400, communication interface

#### Technical specifications

Input	
Analog/digital conversion	
• Measurement rate	< 50 ms
• Resolution	24-bit
<u>Resistance thermometer</u>	
Pt25 ... 1000 to IEC 60751/JIS C 1604	
• Measuring range	-200 ... +850 °C (-328 ... +1562 °F)
Ni25 ... 1000 to DIN 43760	
• Measuring range	-60 ... +250 °C (-76 ... +482 °F)
Cu10 ... 1000, $\alpha = 0.00427$	
• Measuring range	-50 ... +200 °C (-58 ... +392 °F)
Line resistance per sensor cable	Max. 50 $\Omega$
Sensor current	Nominal 0.2 mA
Sensor fault detection	
• Sensor break detection	Yes
• Sensor short-circuit detection	Yes, < 15 $\Omega$
<u>Resistance-based sensors</u>	
Measuring range	0 ... 10 k $\Omega$
Line resistance per sensor cable	Max. 50 $\Omega$
Sensor current	Nominal 0.2 mA
Sensor fault detection	
• Sensor break detection	Yes
• Sensor short-circuit detection	Yes, < 15 $\Omega$
<u>Thermocouple</u>	
to IEC 584	
• Type B	Measuring range 400 ... 1820 °C (752 ... 3308 °F)
• Type E	-100 ... +1000 °C (-148 ... +1832 °F)
• Type J	-100 ... +1000 °C (-148 ... +1832 °F)

• Type K	-100 ... +1200 °C (-148 ... +2192 °F)	
• Type N	-180 ... +1300 °C (-292 ... +2372 °F)	
• Type R	-50 ... +1760 °C (-58 ... +3200 °F)	
• Type S	-50 ... +1760 °C (-58 ... +3200 °F)	
• Type T	-200 ... +400 °C (-328 ... +752 °F)	
to DIN 43710		
• Type L	-200 ... +900 °C (-328 ... +1652 °F)	
• Type U	-200 ... +600 °C (-328 ... +1112 °F)	
to ASTM E988-90		
• Type W3	0 ... 2300 °C (32 ... 4172 °F)	
• Type W5	0 ... 2300 °C (32 ... 4172 °F)	
External cold junction compensation		
Sensor fault detection		
• Sensor break detection	Yes	
• Sensor short-circuit detection	Yes, < 3 mV	
• Sensor current in the event of open-circuit monitoring	4 $\mu$ A	
<u>mV sensor - voltage input</u>		
Measuring range	-800 ... +800 mV	
Input resistance	10 M $\Omega$	
<b>Output</b>		
Filter time (programmable)	0 ... 60 s	
Update time	< 400 ms	
<b>Measuring accuracy</b>		
Accuracy is defined as the higher value of general values and basic values.		
<b>General values</b>		
Type of input	Absolute accuracy	Temperature coefficient
All	$\leq \pm 0.05$ % of the measured value	$\leq \pm 0.002$ % of the measured value/°C
<b>Basic values</b>		
Type of input	Basic accuracy	Temperature coefficient
Pt100 and Pt1000	$\leq \pm 0.1$ °C	$\leq \pm 0.002$ °C/°C
Ni100	$\leq \pm 0.15$ °C	$\leq \pm 0.002$ °C/°C
Cu10	$\leq \pm 1.3$ °C	$\leq \pm 0.02$ °C/°C
Resistance-based sensors	$\leq \pm 0.05$ $\Omega$	$\leq \pm 0.002$ $\Omega$ /°C
Voltage source	$\leq \pm 10$ $\mu$ V	$\leq \pm 0.2$ $\mu$ V/°C
Thermocouple, type: E, J, K, L, N, T, U	$\leq \pm 0.5$ °C	$\leq \pm 0.01$ °C/°C
Thermocouple, type: B, R, S, W3, W5	$\leq \pm 1$ °C	$\leq \pm 0.025$ °C/°C
Cold junction compensation	$\leq \pm 0.5$ °C	
<u>Reference conditions</u>		
Warming-up time	30 s	
Signal-to-noise ratio	Min. 60 dB	
Calibration condition	20 ... 28 °C (68 ... 82 °F)	

# Temperature Measurement

## Transmitters for field mounting

### SITRANS TF fieldbus transmitter

#### Conditions of use

##### Ambient conditions

Permissible ambient temperature	-40 ... +85 °C (-40 ... +185 °F)
Permissible storage temperature	-40 ... +85 °C (-40 ... +185 °F)
Relative humidity	≤ 98 %, with condensation

##### Insulation resistance

• Test voltage	500 V AC for 60 s
• Continuous operation	50 V AC/75 V DC

##### Electromagnetic compatibility

NAMUR	NE21
EMC 2004/108/EC Emission and Noise Immunity	EN 61326-1, EN 61326-2-5

#### Construction

Weight	Approx. 1.5 kg (3.3 lb) without options
Dimensions	See "Dimensional drawings"
Enclosure materials	<ul style="list-style-type: none"> <li>• Die-cast aluminum, low in copper, GD-AISI 12 or stainless steel</li> <li>• Polyester-based lacquer for GD AISI 12 enclosure</li> <li>• Stainless steel rating plate</li> </ul>
Electrical connection, sensor connection	<ul style="list-style-type: none"> <li>• screw terminals</li> <li>• Cable inlet via M20 x 1.5 or ½ -14 NPT screwed gland</li> <li>• Bus connection with M12 plug (optional)</li> </ul>
Mounting bracket (optional)	Steel, galvanized and chrome-plated or stainless steel
Degree of protection	IP67 to EN 60529

#### Auxiliary power

Power supply	
• Standard, Ex "d", Ex "nA", Ex "nL", XP, NI	10.0 ... 32 V DC
• Ex "ia", Ex "ib"	10.0 ... 30 V DC
• In FISCO/FNICO installations	10.0 ... 17.5 V DC
Power consumption	< 11 mA
Max. increase in power consumption in the event of a fault	< 7 mA

#### Certificates and approvals

Explosion protection ATEX	
EC type test certificate	ZELM 99 ATEX 0007
• Type of protection "intrinsic safety i" (version: 7NG313x-1xxxx)	II 2(1) G Ex ia IIC T4/T6
Conformity statement	ZELM 07 ATEX 3349
• "Operating equipment that is non-ignitable and has limited energy" type of protection (version: 7NG313x-2xxxx)	II 3 G Ex nA [nL] IIC T4/T6 II 3 G Ex nL IIC T4/T6
EC type test certificate	CESI 99 ATEX 079
• "Flame-proof enclosure" type of protection (version: 7NG313x-4xxxx)	II 2 G Ex d IIC T5/T6 II 1D Ex tD A20 IP65 T100 °C, T85 °C
Explosion protection: FM for USA	
• FM approval	FM 3017742
• Type of protection XP, DIP, NI and S (version 7NG313x-5xxxx)	<ul style="list-style-type: none"> <li>• XP / I / 1 / BCD / T5,T6; Type 4X</li> <li>• DIP / II, III / 1 / EFG / T5,T6; Type 4X</li> <li>• NI / I / 2 / ABCD / T5,T6; Type 4X</li> <li>• S / II, III / 2 / FG T5,T6; Type 4X</li> </ul>
Other certificates	GOST

#### Communication

##### Parameterization interface

• PROFIBUS PA connection	
- Protocol	A&D profile, Version 3.0
- Protocol	EN 50170 Volume 2
- Address (for delivery)	126
- Function blocks	2 x analog
• FOUNDATION fieldbus connection	
- Protocol	FF protocol
- Protocol	FF design specifications
- Functionality	Basic or LAS
- Version	ITK 4.6
- Function blocks	2 x analog and 1 x PID

#### Factory setting

##### for SITRANS TH400 PA

Sensor	Pt100 (IEC)
Type of connection	3-wire circuit
Unit	°C
Failure mode	Last valid value
Filter time	0 s
PA address	126
PROFIBUS Ident No.	Manufacturer-specific

##### for SITRANS TH400 FF

Sensor	Pt100 (IEC)
Type of connection	3-wire circuit
Unit	°C
Failure mode	Last valid value
Filter time	0 s
Node address	22

# Temperature Measurement

## Transmitters for field mounting

**SITRANS TF**  
**fieldbus transmitter**

Selection and Ordering data	Order No.
<b>Temperature transmitter in field enclosure</b> with fieldbus communication and electrical isolation, with documentation on CD	<b>7NG313 - 0</b>
<b>Integrated transmitter</b>	
• SITRANS TH400 with PROFIBUS PA	
- without Ex protection	7 0
- with EEx ia (ATEX)	7 1
- with EEx nAL for zone 2 (ATEX)	7 2
- total device SITRANS TF EEx d <sup>1)</sup>	7 4
- total device SITRANS TF according to FM (XP, DIP, NI, S) <sup>1)</sup> (available soon)	7 5
• SITRANS TH400, with FOUNDATION fieldbus	
- without Ex protection	8 0
- with EEx ia (ATEX)	8 1
- with EEx nAL for zone 2 (ATEX)	8 2
- total device SITRANS TF EEx d <sup>1)</sup>	8 4
- total device SITRANS TF according to FM (XP, DIP, NI, S) <sup>1)</sup> (available soon)	8 5
<b>Enclosure</b>	
• die-cast aluminium	A
• stainless steel precision casting	E
<b>Connections/cable inlet</b>	
• screwed glands M20x1.5	B
• screwed gland s 1/2-14 NPT	C
<b>Mounting bracket and fastening parts</b>	
• none	0
• made of steel	1
• stainless steel	2
<b>Further designs</b>	Order code
Please add <b>"-Z"</b> to Order No. and specify Order code(s) and plain text.	
<b>Customer-specific operating data</b>	<b>Y01<sup>2)</sup></b>
<b>Inscription on measuring point label (TAG plate)</b>	
• Measuring point number/TAG (max. 32 char.)	<b>Y15<sup>3)</sup></b>
• Measuring point description (max. 32 char.)	<b>Y23<sup>3)</sup></b>
• Bus address	<b>Y25<sup>3)</sup></b>
<b>Test report</b> (5 measuring points)	<b>C11<sup>4)</sup></b>
<b>Bus connection</b>	
• M12 plug (metal), without mating connector	<b>M00<sup>5)</sup></b>
• M12 plug (metal), with mating connector	<b>M01<sup>5)</sup></b>
<b>Explosion protection</b>	
Explosion protection EEx ia to INMERTO (Brazil) (only with 7NG313.-1....)	<b>E25</b>
Explosion protection EEx d to INMERTO (Brazil) (only with 7NG313.-4....)	<b>E26</b>

<sup>1)</sup> Without cable gland.

<sup>2)</sup> Y01: Please specify all data that does not correspond to factory settings (see above) (e.g. Y01 = thermocouple element type K; internal cold junction; PA address: 15).

<sup>3)</sup> Y15, Y23, Y25: If no order is placed for Y01, these data are only noted on the measuring point label and are not programmed in the transmitter.

<sup>4)</sup> Can only be ordered together with Y01 (it is essential to specify the measuring range).

<sup>5)</sup> Not available for explosion protection EEx d or XP.

Selection and Ordering data	Order No.
<b>Accessories</b>	
<b>CD for measuring instruments for temperature</b>	<b>A5E00364512</b>
with documentation in German, English, French, Spanish, Italian and Portuguese, and parameterization software SIPROM T (included in delivery with SITRANS TF)	
<b>SIMATIC PDM parameterization software</b> also for SITRANS TF with TH400 PA	<b>see Sec. 9</b>
<b>Mounting bracket and fastening parts</b>	
• Made of steel for 7NG313.-.B..	<b>7MF4997-1AC</b>
• Made of steel for 7NG313.-.C..	<b>7MF4997-1AB</b>
• Made of stainless steel for 7NG313.-.B..	<b>7MF4997-1AJ</b>
• Made of stainless steel for 7NG313.-.C..	<b>7MF4997-1AH</b>
<b>Connection board</b>	<b>A5E02391790</b>

► Available ex stock.

### Factory setting:

- for SITRANS TH400 PA:
  - Pt100 (IEC) with 3-wire circuit
  - Unit: °C
  - Failure mode: last valid value
  - Filter time: 0 s
  - PA address: 126
  - PROFIBUS Ident No.: manufacturer-specific
- for SITRANS TH400 FF:
  - Pt100 (IEC) with 3-wire circuit
  - Unit: °C
  - Failure mode: last valid value
  - Filter time: 0 s
  - Node address: 22

# Temperature Measurement

## Transmitters for field mounting

### SITRANS TF fieldbus transmitter

#### Dimensional drawings

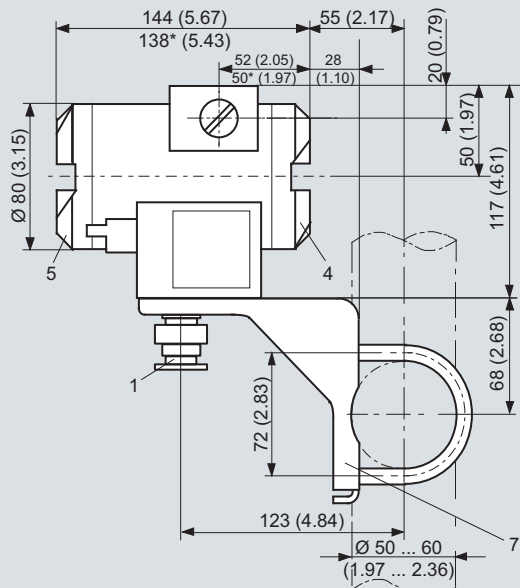

- 1 Sensor connection (screwed gland M20x1,5 or ½-14 NPT)
- 2 Blanking plug
- 3 Electrical connection (screwed plug M20x1,5 or ½-14 NPT), optional M12 plug
- 4 Terminal side, bus connection

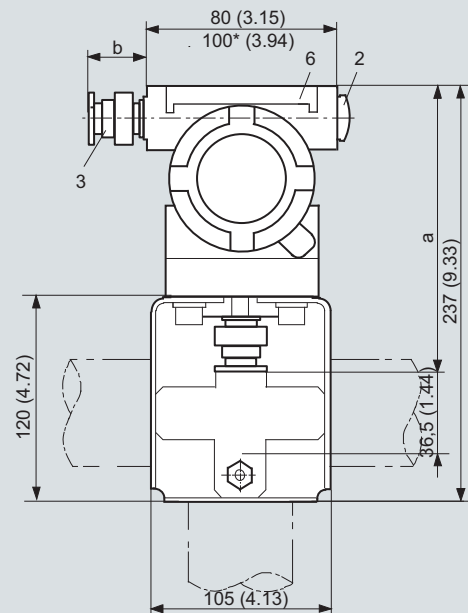

- 5 Terminal side, sensor
- 6 Protective cover (without function)
- 7 Mounting bracket (optional) with clamp securing to a vertical or horizontal pipe

SITRANS TF with TH400, dimensions in mm (inches)

**Schematics**

3

**Resistance thermometer**

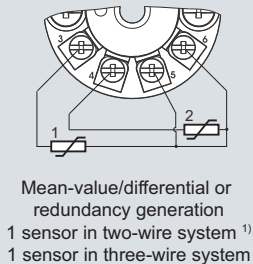
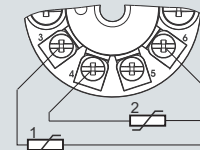
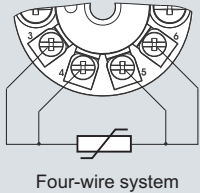
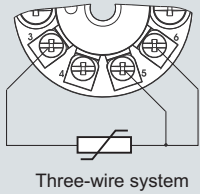
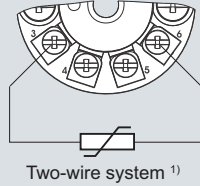

<sup>1)</sup> Programmable line resistance for the purpose of correction.

**Thermocouple**

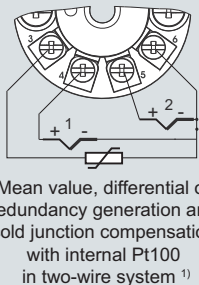
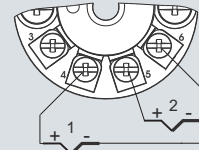
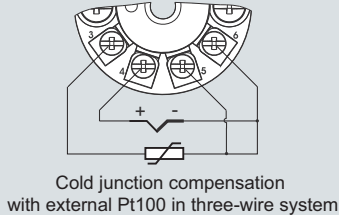
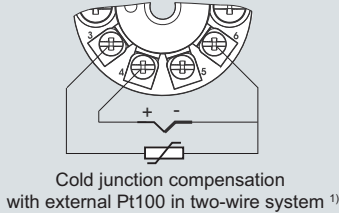
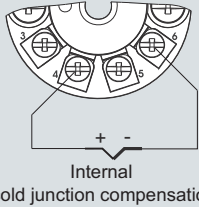

**Resistance**

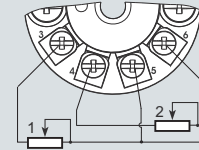
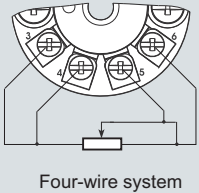
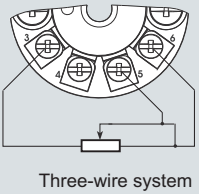
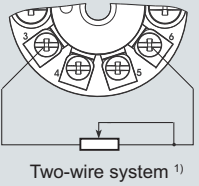

**Voltage measurement**

